

**SENTINEL™**

# 880

SERIES SOURCE PROJECTOR



## Operating and Maintenance Manual

**DELTA** **ELITE**  
150 Ci 50 Ci

**ATLA** **SOMEGA**  
27 Ci 15 Ci





## DANGER - IMPORTANT WARNINGS



The system must be operated only by trained and qualified radiographers who have read and understand this Operating Manual or by trained assistants working under their direct supervision.

### WARNING

**The use of this radiographic exposure device by unqualified personnel or when safety procedures are not fully met could result in life-threatening dangers.**

Gamma radiography systems emit high levels of highly penetrating radiation during use.

An unshielded radiation source at close range can cause **injury, sickness or death** to anyone who is exposed to it even for a short period of time. A radiation source (or an unshielded source assembly) must **NOT** be touched by the hands under any circumstances. Since gamma radiation cannot be detected by the human senses, strict operating and emergency procedures must be followed. The proper use of calibrated and operable survey meters must be employed to avoid potentially dangerous levels of radiation exposure.

Proper dosimetry including film badges or thermoluminescent dosimeters, direct reading pocket dosimeters and audible alarm ratemeters must be worn during all radiographic operations.

During use of this radiography system, **never** assume the position of the radiation source. **Always** conduct a thorough confirmatory survey using a calibrated and operable survey meter to verify the location of the radiation source. Additional radiological considerations are mandatory whenever using low-energy Ytterbium-169 gamma sources or low-activity Iridium-192, Selenium-75 and Cobalt-60 sources. It's extremely important that radiographers conduct careful and deliberate confirmatory surveys after terminating each radiographic exposure. The confirmatory survey includes measuring the radiation levels on the surfaces of the exposure device, the entire length of source guide tube and exposure head/collimator as applicable.

Further considerations take into account the fact that an empty DU shielded exposure device will measure between 10  $\mu\text{Sv/hr}$  to 30  $\mu\text{Sv/hr}$  (1 to 3 mR/hr), therefore, the radiographer must conduct these deliberate and thorough surveys to positively confirm if the low-energy or low-activity source assembly has been properly secured and shielded within the exposure device.

Be reminded that a multitude of overexposure incidents which include injuries are directly attributed to a failure of the radiographer to perform or supervise an adequate confirmatory survey.

It is imperative that the users of this transport container perform adequate radiation surveys of the transport container and exposure devices. Surveys must be performed using a calibrated survey instrument before, during and after source exchanges and before transport to determine if the source assembly is properly shielded within the transport container. Again, the failure to perform an adequate radiation survey can cause unnecessary exposure to personnel resulting in a reportable incident.

It is very important and required by national and international regulations to prevent access by unauthorized persons to radiographic equipment and to the area where radiography is performed.

Take advantage of the three basic radiation protection methods to minimize radiation exposure:

### TIME

Spend less time near the radiation source.

### DISTANCE

Increase your distance in a direction away from the radiation source.

### SHIELDING

When possible, always apply the use of effective shielding between you and the radiation source.



## **DANGER - IMPORTANT WARNINGS**



Do not perform any unauthorized modifications to the radiographic exposure device or components of the radiography system.

It is important that trained and qualified radiographers perform or supervise a daily safety inspection of the radiography system for obvious defects prior to operation of the system.

Do not use any components that are not approved for use with the radiography system or after-market components that may compromise the safety features designed into the system.

## CONTENTS

---

<b>1</b>	<b>TECHNICAL SPECIFICATIONS</b>	<b>1.1 – 1.9</b>
----------	---------------------------------	------------------

---

<b>2</b>	<b>OPERATING INSTRUCTIONS</b>	<b>2.1 – 2.11</b>
----------	-------------------------------	-------------------

---

<b>3</b>	<b>DAILY INSPECTION INSTRUCTIONS</b>	<b>3.1 – 3.10</b>
----------	--------------------------------------	-------------------

---

<b>4</b>	<b>MAINTENANCE INSTRUCTIONS</b>	<b>4.1 – 4.35</b>
----------	---------------------------------	-------------------

---

<b>5</b>	<b>SAMPLE TRANSPORTATION INSTRUCTIONS</b>	<b>5.1 – 5.14</b>
----------	---	-------------------

---

<b>6</b>	<b>DEFINITIONS AND TERMS</b>	<b>6.1 – 6.3</b>
----------	------------------------------	------------------

---

<b>7</b>	<b>EMERGENCIES AND PERSONNEL SAFETY</b>	<b>7.1 – 7.2</b>
----------	---	------------------

---

<b>8</b>	<b>INSTRUCTIONS FOR DISPOSAL</b>	<b>8.1</b>
----------	----------------------------------	------------

---

## 880 Delta 150 Ci (5.55 TBq)

Maximum package weight  
 With jacket 52 lb (24 kg)  
 Without jacket 46 lb (21 kg)

## 880 Elite 50 Ci (1.85 TBq)

Maximum package weight  
 With jacket 42 lb (19 kg)  
 Without jacket 37 lb (17 kg)

## 880 Omega\*\* 15 Ci (0.55 TBq)

Maximum package weight  
 With jacket 33 lb (15 kg)  
 Without jacket 28 lb (13 kg)

\*\* (880 Omega is a Type A transport container)

## 880 Sigma\* 130 Ci (4.81 TBq)

Maximum package weight  
 With jacket 52 lb (24 kg)  
 Without jacket 46 lb (21 kg)

\* (No longer manufactured)

## 880 Atlas\*\* 27 Ci (1 TBq)

Maximum package weight  
 With jacket 53 lb (24 kg)  
 Without jacket 47.5 lb (22 kg)

\*\* (880 Atlas is tungsten shielded Type A transport container)

FRONT VIEW  
 Outlet Port  
 Guide Tube Connector



REAR VIEW  
 Locking Mechanism  
 Remote Control Connector

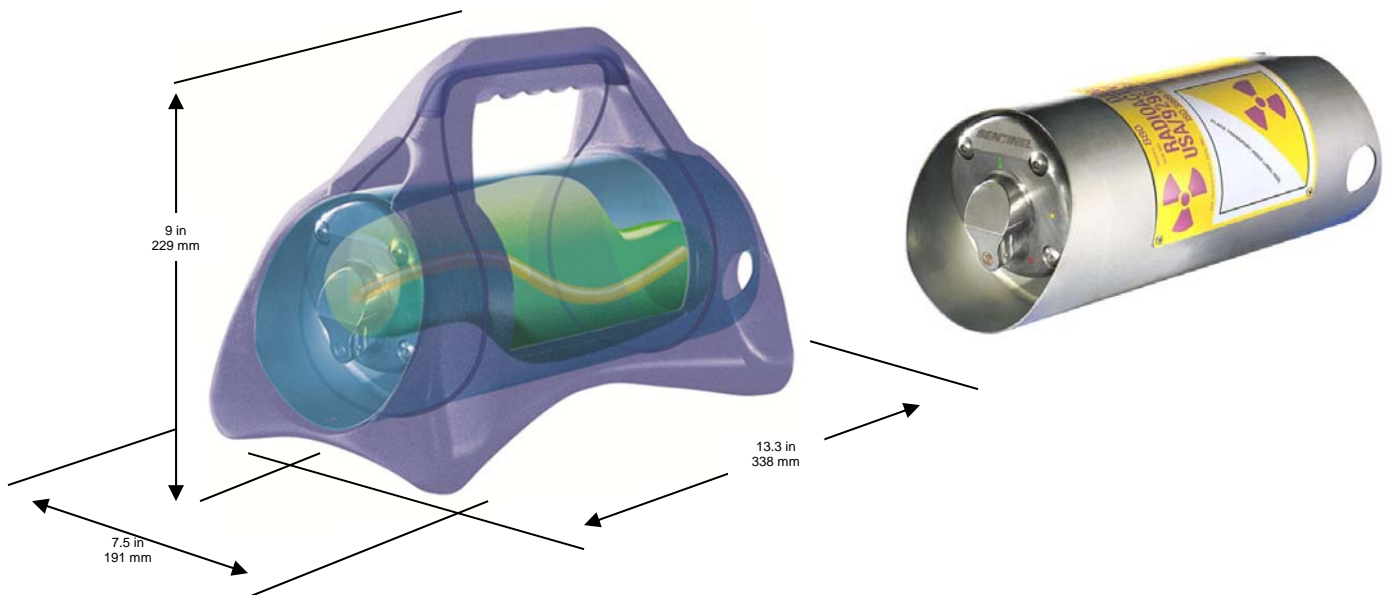

### Exposure Device Description

The Model 880Delta, Model 880 Sigma, Model 880 Elite and Model 880 Omega are physically small, lightweight, portable industrial radiographic exposure devices. The 'S' tube design exposure device consists of a cast depleted Uranium (DU) shield contained and secured within a 300 series stainless steel tube with stainless steel discs welded at each end to form a cylinder shaped housing. Both discs are recessed into the stainless steel tube to provide protection for the locking mechanism at the rear side and the outlet port at the front side.

The welded tubular housing is oriented horizontally to provide easy access to the locking mechanism and source assembly connector and to provide easy access to the outlet port for connection of the projection sheaths. The internal void space of the welded housing is filled with polyurethane foam to prevent the ingress of water or foreign material but is open to atmospheric pressure. The stainless steel housing containing the DU shield, locking mechanism, outlet port, protective covers and required labels comprise the radioactive material transport package.

A plastic jacket surrounds the welded housing and serves as a protective barrier for the labels and provides the means for carrying and placement during use as a radiographic exposure device. The Model 880 Delta is identified by a yellow colored jacket. The Model 880 Sigma (no longer manufactured) is identified by a black colored jacket. The Model 880 Elite is identified by a blue colored jacket and the Model 880 Omega is identified by a safety orange colored jacket. The Model 880 Atlas is identified by a green colored jacket and USDOT Type A label. The plastic jacket incorporates a carrying handle and a base that is used during radiographic operations but is not required for transportation purposes. The plastic jacket may be removed for certain applications such as when the exposure device is securely mounted to a pipe-crawler locomotive or a pipe-liner sled.

The Model 880 Delta, Sigma, Elite, Omega and Atlas exposure devices are designed, tested, and manufactured to meet the requirements of ANSI N432-1980, ISO 3999:2004(E), IAEA TS-R-1 (2009 Edition), USNRC 10CFR34, 10CFR71 and 49CFR173 requirements. Additionally, these exposure devices are designed, manufactured and serviced under an ISO 9001 QA Program and a USNRC 10CFR71, Subpart H QA Program. The QA program also includes the reporting requirements of USNRC 10CFR21 for suppliers of source and byproduct materials. The Model 880 Atlas shield is manufactured from tungsten and does not contain any depleted Uranium.

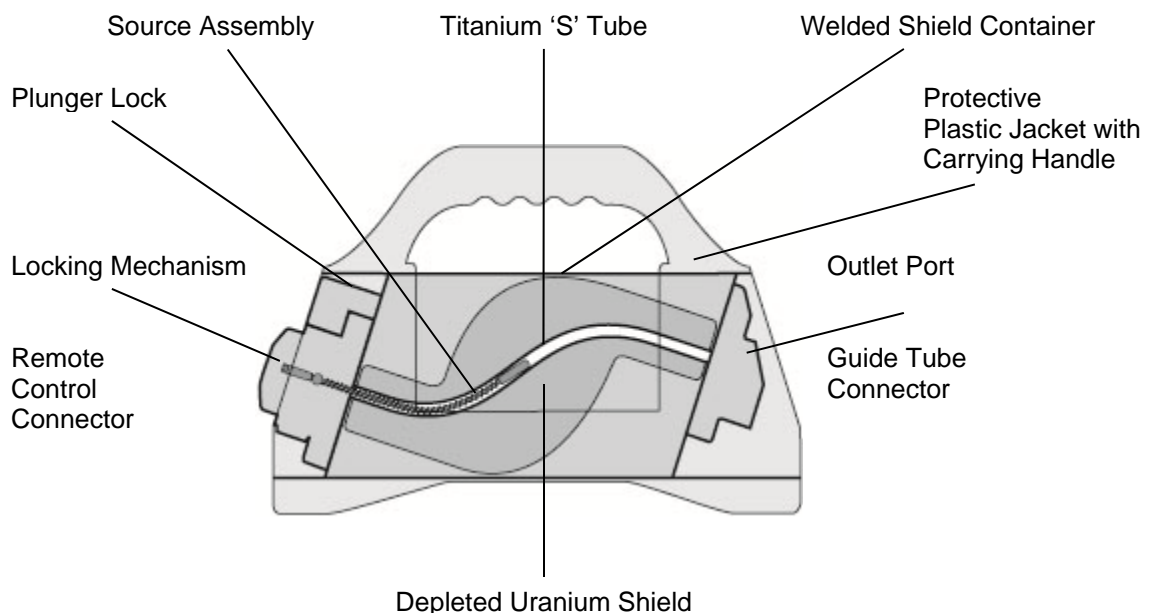

### Applications

The Model 880 devices are used for industrial applications of gamma radiography, mainly with Iridium-192, to inspect materials and structures in the density range of approximately 2.71 g/cm<sup>3</sup> through 8.53 g/cm<sup>3</sup>. The Model 880 devices also accommodate low energy isotopes to permit radiography of materials and structures of thin sections of steel and low-density alloys. The Model 880 exposure devices are also designed for use with low activity sources with high photon energies that are used for mass absorption (gamma scanning) studies of high-density materials up to 18.7 g/cm<sup>3</sup>.

### Standard Source Assembly

Metallic Iridium-192 discs and pellets are doubly encapsulated in welded stainless steel or titanium capsules. The sealed sources are designed and tested to achieve an ISO/ANSI minimum classification of 97C64515 and to comply with the IAEA and USDOT requirements for 'Special Form' radioactive material. The ISO/ANSI classification 97C64515 stated in this manual refers to the complete source capsule which is attached to the source assembly. This classification also applies to the Se-75, Co-60 and Cs-137 versions of the source assemblies.

The sealed source is swaged to one end of a source holder consisting of a short flexible steel cable which has a female half of a connector at the other end, used for coupling to a control cable connector. The female connector also incorporates a stainless steel stop-ball swaged onto it (older versions of this source wire had the stop-ball as a separate component from the female connector). The purpose of the stop-ball is to provide mechanical positioning of the source assembly within the exposure device's shielding and to provide a means of securing the source assembly in the exposure device's locking mechanism.

### Model 880 Delta authorized contents

Isotope	Assembly Model Number	Gamma Energy Range	Half Life	Approximate Steel Working Thickness	Device/Source Maximum Capacity
Ytterbium-169	*	8-308 keV	32 days	2-20 mm	108 Ci 4.00 TBq
Selenium-75	A424-25W A424-25**	66-401 keV	120 days	3-29 mm	150 Ci 5.55 TBq
Iridium-192	A424-9 A424-23**	206-612 keV	74 days	12-63 mm	150 Ci 5.55 TBq
Cobalt-60	A424-19	1.17-1.33 MeV	5.27 years	50-150 mm	65 mCi 2.40 GBq
Cesium-137	A424-30	663 keV	30 years	12-63 mm	380 mCi 14.0 GBq

### Model 880 Sigma authorized contents

Isotope	Assembly Model Number	Gamma Energy Range	Half Life	Approximate Steel Working Thickness	Device/Source Maximum Capacity
Ytterbium-169	*	8-308 keV	32 days	2-20 mm	108 Ci 4.00 TBq
Selenium-75	A424-25W A424-25**	66-401 keV	120 days	3-29 mm	150 Ci 5.55 TBq
Iridium-192	A424-9 A424-23**	206-612 keV	74 days	12-63 mm	130 Ci 4.81 TBq
Cobalt-60	A424-19	1.17-1.33 MeV	5.27 years	50-150 mm	25 mCi 925 MBq
Cesium-137	A424-30	663 keV	30 years	12-63 mm	380 mCi 14.0 GBq

### Model 880 Elite authorized contents

Isotope	Assembly Model Number	Gamma Energy Range	Half Life	Approximate Steel Working Thickness	Device/Source Maximum Capacity
Ytterbium-169	*	8-308 keV	32 days	2-20 mm	108 Ci 4.00 TBq
Selenium-75	A424-25W A424-25**	66-401 keV	120 days	3-29 mm	150 Ci 5.55 TBq
Iridium-192	A424-9 A424-23**	206-612 keV	74 days	12-63 mm	50 Ci 1.85 TBq
Cobalt-60	A424-19	1.17-1.33 MeV	5.27 years	50-150 mm	25 mCi 925 MBq
Cesium-137	A424-30	663 keV	30 years	12-63 mm	380 mCi 14.0 GBq

### Model 880 Omega authorized contents

Isotope	Assembly Model Number	Gamma Energy Range	Half Life	Approximate Steel Working Thickness	Device/Source Maximum Capacity
Ytterbium-169	*	8-308 keV	32 days	2-20 mm	108 Ci 4.00 TBq
Selenium-75	A424-25W A424-25**	66-401 keV	120 days	3-29 mm	80 Ci 2.96 TBq
Iridium-192	A424-9 A424-23**	206-612 keV	74 days	12-63 mm	15 Ci 0.55 TBq

\* Source assemblies with A1 quantities available for use in international jurisdictions.

\*\* Approved for international transport, except in Canada.

### Model 880 Atlas authorized contents

Isotope	Assembly Model Number	Gamma Energy Range	Half Life	Approximate Steel Working Thickness	Device/Source Maximum Capacity
Ytterbium-169	*	8-308 keV	32 days	2-20 mm	108 Ci 4.00 TBq
Selenium-75	A424-25W A424-25**	66-401 keV	120 days	3-29 mm	81 Ci 3.0 TBq
Iridium-192	A424-9 A424-23**	206-612 keV	74 days	12-63 mm	27 Ci 1.0 TBq

\* Source assemblies with A1 quantities available for use in international jurisdictions.

\*\* Approved for international transport, except in Canada.

The tungsten shielded Model 880 Atlas was evaluated as a USDOT Type A transport container. The Model 880 Atlas is NOT approved as a Type B transport package. Labeling for the Model 880 Atlas reflects Type A information for the package instead of the Type B information labeling on all other Model 880 exposure devices.



### Source output

Isotope	At 1 m per Ci (37 GBq)		At 1 ft per Ci (37 GBq)	
	R/hr	mSv/hr	R/hr	mSv/hr
Ytterbium-169	0.125 R/hr	1.25 mSv/hr	1.3 R/hr	13.0 mSv/hr
Selenium-75	0.203 R/hr	2.03 mSv/hr	2.2 R/hr	22.0 mSv/hr
Iridium-192	0.48 R/hr	4.80 mSv/hr	5.2 R/hr	52.0 mSv/hr
Cobalt-60	1.30 R/hr	13.0 mSv/hr	14.0 R/hr	140 mSv/hr
Cesium-137	0.32 R/hr	3.20 mSv/hr	3.4 R/hr	34.0 mSv/hr

### Selected attenuation data

Material	Approximate Material Density (g/cm <sup>3</sup> )	Approximate Half Value Thickness Inches (mm)				
		Ytterbium-169	Selenium-75	Iridium-192	Cobalt-60	Cesium-137
Concrete	2.35	1.140 (29.0)	1.180 (30.0)	1.700 (43.2)	2.400 (61.0)	3.00 (76.2)
Aluminum	2.65	-	1.100 (27.0)	-	-	-
Steel	7.80	0.170 (4.3)	0.315 (8.0)	0.512 (13.0)	0.827 (21.0)	0.900 (22.9)
Lead	11.34	0.032 (0.8)	0.039 (1.0)	0.200 (5.1)	0.500 (12.7)	0.250 (6.4)
Tungsten	17.80	-	0.032 (0.8)	0.130 (3.3)	0.310 (7.9)	0.225 (5.7)
DU	18.70	-	-	0.050 (1.3)	0.270 (6.8)	0.125 (3.2)

### Operating Distance

The separation distance between the remote control and the exposure head is determined by summing the length of the remote control conduits plus the total length of source guide tubes used, and normally should not exceed 47 ft (14.2 m) with standard length 25 ft. controls.

Standard lengths of remote controls:  
25 ft (7.6 m), 35 ft (10.7 m), 50 ft (15 m)

Standard lengths of source guide tubes (projection sheaths):  
7 ft (2.1 m) set of three source guide tubes: 21 ft total (6.3 m)

**Note:** The total length of source guide tubes utilized **must be shorter** in length than the remote controls to ensure the source assembly will project into the working position.

e.g. When using 25 ft (7.6 m) remote controls, a maximum of three 7 ft (2.1 m) source guide tubes can be used with a combined length of 21 ft (6.4 m).

Conversely, when using 35 ft (10.7 m) remote controls, a maximum of four 7 ft (2.1 m) source guide tubes can be utilized.

When using 50 ft (15 m) remote controls, a maximum of six 7 ft (2.1 m) source guide tubes can be utilized. This limitation is due to the weight and friction of remote control cable length.

### Control Specifications

#### Complete Remote Control Assemblies

Product code	Model number	Control conduit length	Unit weight
TAN66425	664/25	25 ft (7.6 m)	21 lb (10 kg)
TAN66435	664/35	35 ft (10.7 m)	24 lb (11 kg)
TAN66450	664/50	50 ft (15.2 m)	27 lb (12 kg)
TAN69325	693/25	25 ft (7.6 m)	21 lb (10 kg)
TAN69335	693/35	35 ft (10.7 m)	24 lb (11 kg)
TAN69350	693/50	50 ft (15.2 m)	27 lb (27 kg)
TAN69225	692/25	25 ft (7.6 m)	21 lb (10 kg)
TAN69235	692/35	35 ft (10.7 m)	24 lb (11 kg)
TAN69250	692/50	50 ft (15.2 m)	27 lb (12 kg)
SAN88225	882/25	25 ft (7.6 m)	14 lb (6 kg)
SAN88235	882/35	35 ft (10.7 m)	17 lb (8 kg)
SAN88250	882/50	50 ft (15.2 m)	22 lb (10 kg)
SAN88225R	88225R	25 ft (7.6 m)	14 lb (6 kg)
SAN88235R	88235R	35 ft (10.7 m)	17 lb (8 kg)
SAN88250R	88250R	50 ft (15.2 m)	22 lb (10 kg)
SAN88525	88525	25 ft (7.6 m)	18 lb (8kg)
SAN88535	88535	35 ft (10.7 m)	21 lb (9 kg)
SAN88550	88550	50 ft (15.2 m)	26 lb (12 kg)

#### Model 664 Series and 885 Series Control Storage Reel Unit Size

Length	Width	Height
21 in (533 mm)	12 in (305 mm)	6.6 in (168 mm)

The Model 664 reel and 693 pistol grip controls are equipped with odometers. The Model 692 pistol-grip, Model 882 series and Model 885 reel-type remote controls are not equipped with an odometer.

### Source Guide Tube (with source stop)

Product Code	Model Number	Length
TAN48906	48906	7 ft (2.1 m) male 1-18 threaded fitting
48906-X	48906-X	Customer specified length
48931-7	48931-7	7 ft (2.1 m) with bayonet fitting
48931-X	48931-X	Customer specified length with bayonet fitting
95020	95020	7 ft (2.1m) male 1-18 threaded fitting*
95020-X	95020-X	Customer specified length*

### Source Guide Tube Extension

Product Code	Model Number	Length
TAN48907	48907	7 ft (2.1 m) male/female 1-18 threaded fittings
48930-7	48930-7	7 ft (2.1 m) bayonet fitting/female 1-18
48930-X	48930-X	Customer specified length bayonet fitting/female 1-18
95021	95021	7 ft (2.1 m) male/female 1-18 threaded fittings*
95021-X	95021-X	Customer specified length*

**NOTE:** X indicates customer can order lengths other than the standard length.

\* indicates source guide tube material for extreme condition use.

## Exposure Device Specifications

### Manufacturer

QSA Global, Inc.  
40 North Avenue, Burlington, Massachusetts, USA 01803

### Primary Application

Industrial gamma radiography

### Model Numbers

Model 880 Delta, Model 880 Sigma, Model 880 Elite,  
Model 880 Omega and Model 880 Atlas

### Weight of Exposure Device

Delta: 52 lb (24 kg), Sigma: 52 lb (24 kg)  
Elite: 42 lb (19 kg), Omega: 33 lb (15 kg)  
Atlas: 53 lb (24 kg)

### Weight of Depleted Uranium Shield

Delta: 34 lb (15.4 kg), Sigma: 34 lb (15.4 kg)  
Elite: 25 lb (11.4 kg), Omega: 17 lb (7.7 kg)  
Atlas: Tungsten shielded, does not contain DU

### Activity of Depleted Uranium Shield

Delta: 5.4 mCi (200 MBq), Sigma: 5.4 mCi (200 MBq)  
Elite: 3.8 mCi (141 MBq), Omega: 2.7 mCi (101 MBq)  
Atlas: Tungsten shielded, does not apply

### Special Form Certifications

Iridium-192, Ytterbium-169, Cobalt-60: USA/0335/S-96  
& Cesium-137  
Iridium-192: USA/0392/S-96  
Selenium-75: USA/0502/S-96

## TECHNICAL SPECIFICATIONS

### Length

13.33 in (33.8 cm) all models

### Width

7.5 in (19.1 cm) all models

### Height

9 in (22.9 cm) all models

### Type B (U) Certification

The Models 880 Delta, 880 Sigma and  
880 Elite are certified by the following:  
USA/9296/B(U)-96  
CDN/E199/-96

### Type A Approval

All Models meet the Type A package  
requirements of 49 CFR 173.415 and  
IAEA TS-R-1 (2009 Edition)

**Construction**

A depleted Uranium (DU) or Tungsten (W) shield is encased within a welded tubular stainless steel shell with stainless steel end plates. The interior void space is filled with rigid polyurethane foam. The exposure device body is encased in an engineered plastic jacket also consisting of the handle and a base.

**Materials**

Titanium 'S' tube, DU shield, Tungsten shield, 300 series stainless steel tubular shell and plate, aluminum, brass, tungsten and polyurethane.

**Maximum Capacities**

See previous table listings in this section.

**Inspection Requirements**

Daily pre-operational inspection for obvious damage to the system.

**Maintenance Requirements**

Most national regulations require inspection and maintenance of the system at quarterly intervals. The complete annual servicing ensures the integrity of the system. Shorter frequencies of inspection and maintenance are required when the system is operated under severe operating environments. In some cases, the system should be serviced immediately after certain jobs in severe environmental working conditions.

**Device Operating Temperature Range**

-40°F to 300°F (-40°C to 149°C)

**Source Assembly**

See previous table listings in this section.

**NOTICE**

These industrial radiography systems are used as an exposure device, a Type A shipping container and for the Models 880 Delta, 880 Sigma and 880 Elite as Type B(U)-96 shipping containers for QSA Global, Inc. source assemblies. The Models 880 Omega and 880 Atlas are radiography exposure devices and USDOT Type A shipping packages. The purpose of this manual is to provide information that will assist qualified radiographers in using the Model 880 Delta, 880 Sigma, 880 Elite, 880 Omega and 880 Atlas gamma radiography systems. The user must be thoroughly familiar with this instruction manual before attempting operation and use of this equipment.

In order to use this equipment or perform source changes, users within the USA must be specifically licensed to do so. Applications for a license should be filed with the Materials Licensing Section of the appropriate U.S. Nuclear Regulatory Commission regional office or with the appropriate Agreement State office. All users within Canada must have a Canadian Nuclear Safety Commission license.

Prior to the initial use of the exposure device as a shipping container, the user must register with the Office of Nuclear Material Safety and Security, U.S. Nuclear Regulatory Commission. The user should have in his possession a copy of the Certificate of Compliance issued for the exposure device, which may be obtained from Sentinel, QSA Global, Inc. customer service centers upon request. This also applies to users from Agreement States and other regulatory jurisdictions.

It is the responsibility of users of this equipment outside of the United States to comply with all local, national and international regulatory, licensing and transportation rules and regulations as they apply in their respective countries.

### **Warranty and Limitation of Liability**

QSA Global, Inc. (herein referred to as the manufacturer) warrants its product which it manufactures and sells to be free from defects in material and workmanship for a period of one year from the date of shipment. This warranty shall not apply to any product or parts which have been subjected to misuse, improper installation, repair, alteration, neglect, accident, abnormal conditions of operation, or use in any manner contrary to instructions.

The manufacturer's liability under such warranty shall be limited to replacing or repairing, at its option, any parts found to be defective in such respects, which are returned to the manufacturer, transportation prepaid; or at its option, to returning the purchase price thereof.

The warranty on other manufacturer's components shall be that of the original manufacturer whose warranty shall be binding.

In no event shall the manufacturer be liable for any incidental or consequential damages, whether or not such damages are alleged to have resulted from the use of such product in accordance with instructions given by or referred to by the manufacturer.

QSA Global, Inc. assumes no liability or responsibility for the usage of any radioactive material or device generating penetrating radiation used in connection with this product. The use of such material or generators in any manner other than prescribed in the U.S. Nuclear Regulatory Commission or equivalent Agreement State or permitted by any regulation of the U.S. Nuclear Regulatory Commission or State Regulation may constitute a violation of such license terms.

All other warranties, except those warranties expressly stated herein, including without limitation warranties of, merchantability and implied warranties of fitness, are expressly excluded.

The warranty on this device is specifically limited to its use only with sealed sources and connectors, parts, and accessories manufactured by QSA Global, Inc.

QSA Global, Inc. has received equipment approvals for the Model 880 Delta, Model 880 Sigma and Model 880 Elite systems from the Commonwealth of Massachusetts, the USNRC Transportation Branch, the U.S. Department of Transportation, and the Canadian Nuclear Safety Commission. (The Model 880 Omega and Model 880 Atlas are authorized by the Commonwealth of Massachusetts for use in the USA. Neither the Model 880 Omega nor the Model 880 Atlas are currently approved for use in Canada). The equipment approvals require the use of Agreement State or USNRC registered and approved remote controls, control cables, projection sheaths, sealed source assemblies, and remote control cranks in conjunction with the Model 880 Delta, Model 880 Sigma, Model 880 Elite, Model 880 Omega and Model 880 Atlas. For additional information on compliance with Type B(U)-96 or Type A certifications, USNRC 10CFR34, ANSI N432-1980 or ISO 3999: 2004(E) please contact QSA Global, Inc.

Sentinel™, QSA Global, Inc. shall not be liable for any errors or omissions contained herein and the provision by Sentinel™, QSA Global, Inc. of the information set out in this manual does not in itself constitute acceptance of any liability on the part of Sentinel™, QSA Global, Inc.

### Job site safety precautions

#### Instruments

The radiographer and radiography assistants must at all times wear a film badge or TLD and pocket dosimeter with a range of 0-2 mSv (0-200 mRem). Regulatory requirements in the USA also require that an audible alarm ratemeter be worn at temporary jobsites. Specifically, those locations that are not permanent radiographic installations equipped with functional door interlocks and audible/visual alarms.

Radiographers in the USA must also have a survey meter capable of measuring in the range 20  $\mu$ Sv/hr (2 mR/hr) up to 10 mSv/hr (1,000 mR/hr). Canadian regulations require that survey meters used for industrial radiography be capable of measuring from 2  $\mu$ Sv/hr (0.2 mR/hr) and up to 100 mSv/hr (10 R/hr). In any regulatory jurisdiction, always verify survey meter requirements affecting the range and calibration requirements prior to engaging in industrial radiography operations.

An audible 'chirper' pocket alarm may be required in some countries.

#### Restricted Area

Radiography must be performed only in a restricted area that is marked with the appropriate radiation warning signs and secured against unauthorized entrance.

#### Distance

Since the source emits high levels of radiation it is good practice to operate the system from as great a distance as possible.

#### Shielding

Whenever possible, situate the radiographic exposure area in a room with suitably thick walls, floor, ceiling and doors. Whenever possible, the use of a collimator (beam limiter) provides effective shielding to reduce radiation levels outside of the central beam. It is recommended that collimators be used at temporary job sites to minimize occupational exposure to radiation.

#### Surveillance

Only trained and qualified radiographers or assistants working under their direct supervision may operate radiography systems. The radiographer must be physically present at the site and able to control and limit access to the restricted area.

#### Locking

Keep the exposure device locked while assembling the system and when not being used to perform radiography. Locked is defined as the exposure device's lock is fully engaged with the key removed. Store the key in a secured location.



It is essential that the 5 STEPS set out below are followed in the correct order to ensure safe operation and compliance with regulations.



- STEP 1 Exposure Device Survey
- STEP 2 Connecting the Source Guide Tube(s)
- STEP 3 Connecting the Remote Control Cable
- STEP 4 Projecting and Retracting the Source Assembly
- STEP 5 Dismantling Equipment

## STEP 1

### Exposure Device Survey

Check the operation of the survey meter by measuring the radiation level at the surface of the exposure device. The radiation level measurement should not exceed 2 mSv/hr (200 mR/hr) on any surface of the exposure device. Use this measurement for verification surveys of the source assembly's return to the fully shielded/secured position within the exposure device after each radiographic exposure.

## STEP 2

### Source Guide Tube (projection sheath) Layout

Ensure all source guide tubes that will be utilized have received a daily inspection according to the daily inspection section of this manual. Position and secure the source stop (exposure head) of the terminating source guide tube at the radiographic focal position using the tripod stand and swivel clamps or some other secure and suitable means.

Ensure that a source stop (end stop) is in place on the terminating source guide tube.

Use a collimator (beam limiter) to limit the primary beam in unwanted directions.

Determine where the exposure device will be positioned and lay out the source guide tubes as straight as possible, with no bend radius less than 20 in (0.5 m) to avoid restricting the movement of the source assembly.

Make sure that the source guide tubes do not contact any heated surface greater than 140°F (60°C).

Avoid any risk of crushing the source guide tube(s) by falling objects, vehicles or doorways during set-up and during radiographic exposure.

### Connecting the Source Guide Tube(s)

The source guide tubes must always be attached to the outlet port of the device before connecting the remote controls in the set-up for a radiographic exposure.

Connect the source guide tube(s) to the exposure device outlet port as shown.





### STEP 2

#### Connecting the Source Guide Tube(s)



1 Simultaneously pull and rotate the spring-loaded outlet port cover a quarter of a turn in a clockwise direction.



2 Insert the bayonet fitting of the source guide tube into the exposed outlet port.

Align the **GREEN MARKINGS** on the bayonet fitting and outlet port.



3 Rotate a quarter of a turn counter-clockwise.



4 Rotate the spring-loaded outlet port cover an additional 60 degrees in a clockwise direction until it stops.

### STEP 2

#### WARNING

Ensure that the available length of the control cable is greater than the total length of the source guide tubes. See the technical specifications section for details.

If the remote control conduits are shorter than the total length of the source guide tubes:

- 1 The source assembly **cannot** be projected all the way to the source stop of the terminating source guide tube and be correctly positioned for the exposure.
- 2 The source assembly may **not** reach a collimator; therefore, restricted area dose rates may be higher than expected.
- 3 The control cable end may be cranked beyond the drive wheel of the remote controls if the drive cable is not be fitted with a safety retaining spring. This scenario must be treated as an **EMERGENCY**.

### STEP 3

#### Remote Control Conduit Layout

Lay out the remote control conduits as straight as possible, with no bend radii less than about 36 in (approximately 1 m).

Avoid any risk of crushing the remote control conduits by falling objects, moving vehicles or closing doors, etc.

The remote control crank mechanism (operator's hand-crank) should be placed as far away from the source focal position as possible (preferably behind shielding).

#### Connecting the Remote Control Cable

Connect the control cable to the source projector as shown.

### STEP 3

#### Connecting the Remote Control Cable



Unlock the plunger lock with the key.



Turn the selector ring from LOCK to CONNECT



The protective cover will disengage from the projector.

### STEP 3

#### Connecting the Remote Control Cable



Insert the protective cover into the lock housing during use of the device.

Check the control cable and source assembly connectors using the NO GO gauge according to the daily inspection section.



Remove the protective rubber cap from the remote control connector.

#### **IMPORTANT WARNING**

**The control cable connector is made from hardened steel and should never be left unprotected or forced into connection with the source assembly as this could damage the connector overtime leading to possible breakage during use.**



**ALWAYS use the protective end-cover when remote controls are not connected to the exposure device and ALWAYS manually move the sleeve of the female connector of the source assembly to the OPEN position when connecting and disconnecting the control cable from the source assembly.**

Slide the remote control connector assembly's collar back and open the jaws to expose the male portion of the control cable connector (i.e. the ball-end on the control cable connector).



Press back the spring-loaded locking pin of the source assembly connector with a thumb-nail and engage the male and female portions of the connectors.

Release the locking pin of the source assembly connector and check that the connection is secure.

Use the NO GO gauge to check the gap between the joined connectors during the daily inspection.

### STEP 3

#### Connecting the Remote Control Cable

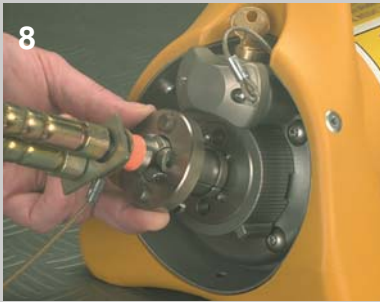

Close the jaws of the control cable connector over the joined connectors.

Slide the remote control connector assembly collar over the connector jaws.

**NOTE:** The control cable connector, when properly installed with the selector ring in the CONNECT position, displaces anti-rotation lugs which allows the selector ring to be rotated to the LOCK position and when required, through to the OPERATE position.



Push and hold the remote control connector assembly collar flush against the exposure device's locking mechanism and rotate the selector ring from CONNECT to LOCK. The selector ring can be secured in this position by engaging the plunger lock.

**Do Not Rotate past LOCK.**

The remote control cable connector is now secured into the exposure device's locking mechanism.

Keep the exposure device in the lock position until ready to start the exposure.

#### Checks Before Exposure of the Source

Verify that the source guide tubes are attached to the outlet port.

Verify that the remote control connector assembly is correctly connected to the exposure device's locking mechanism.

Ensure that no personnel are inside the Restricted Area or exposure room.

Ensure that the proper signs are posted and required warnings are in operation.

#### NOTE

If the remote control is fitted with an additional lock, release this lock and apply a forward motion to control crank handle, as if exposing the source, until a resistance is felt. Release the control crank handle and proceed with the next step.

#### CAUTION

Do not apply excessive force to the control crank handle in the expose direction as this could cause the source assembly to move forward out of the stored position when the lock slide is released. Do not retract the control cable and apply the control crank brake. Leave the control crank and the control cable in a neutral tension position.

### STEP 4

#### Projecting and Retracting the Source Assembly



#### Unlocking

If engaged, unlock the exposure device's plunger lock with the key.



Rotate the selector ring to the OPERATE position.

Ensure there is no tension/force in either direction on the control cable.



Push the lock slide **GREEN MARKING** laterally from left to right (as seen behind the projector) until the lock slide **RED MARKING** fully appears on the right side of the selector ring and you feel or hear the sleeve snap into the slide.

When the **GREEN MARKING** is visible, the source assembly is locked into the secured position within the exposure device.



When the **RED MARKING** is visible, the source assembly is free to be projected from, and retracted to, the projector. Ensure all personnel leave the immediate area.

Got to the remote control crank.

If an odometer is fitted, adjust the reset knob to read zero.

The source assembly can now be projected.

**STEP 4****Projecting**

Rapidly rotate the control crank handle in the EXPOSE direction (counter-clockwise) to move the source assembly out of the exposure device to the radiographic focal position.

The control crank handle will stop turning when the source reaches the source stop. Do not use excessive force.

The odometer (if fitted) will indicate the approximate total distance traveled, 7 ft (2.1 m) for each guide tube section.

Set the brake to ON to prevent movement of the source assembly during the radiographic exposure.

Start timing the radiographic exposure from the moment the source assembly reaches the exposure head.

Survey meter readings observed during the projection operation should increase rapidly from background to a high level as the source emerges from the projector. Then readings should fall as the source moves out towards the focal point, fall sharply as the source enters a collimator (if used) and remain steady throughout the exposure.

Actual survey meter readings will depend on the source activity, distance, collimators and shielding. The sequence of changes should be observed and the readings noted.

During retraction of the source assembly from the exposure head to the exposure device, the sequence will reverse. The survey meter should indicate a continually increasing radiation level as the source assembly is retracted, then drop to background when the source assembly is stored in the exposure device.

During the radiographic exposure, use the survey meter to check the boundary dose rate, but spend as little time as possible in and near the restricted area to minimize personal exposure.

## STEP 4

### Retracting

At the end of the required exposure time, set the brake to OFF and rapidly turn the crank handle in the RETRACT (clockwise) direction until it no longer moves. You may hear the lock slide 'click' back into its original position depending on the ambient noise level at the job site. From the control crank you may be able to observe the **GREEN MARKING** on the slide bar.

Apply a slight amount of forward pressure on the crank handle as if to expose the source to ensure that the positive locking mechanism has actuated.

Allow the crank handle to return to a neutral position, thereby relieving any tension (force) on the control cable that would cause source movement when unlocking the projector. At this point the source cannot be moved out of the stored position.

In the unlikely event the lock slide moves toward the lock position before the source is fully stored in the exposure device, turn the crank handle in the RETRACT (clockwise) direction until it stops turning. (The lock slide is designed to lock on the stop ball, not the control cable). Do not use excessive force. The source assembly will be in the exposure device but not in the fully shielded position. Approach the exposure device, from the rear, with a survey meter. The survey meter will measure approximately 400  $\mu\text{Sv/hr}$  (40 mR/hr) at the rear plate of the exposure device when a 3.7 TBq (100 Ci) Ir-192 source is in use.

### CAUTION

Remain clear of the front of the exposure device (outlet port side) to minimize personal exposure. Reset the lock slide to the open position. Return to the control crank and turn the crank handle in the RETRACT (clockwise) direction and store the source assembly in the normal manner.

The odometer (if supplied) should read approximately zero when the source assembly has returned to the projector.

### Confirmatory Survey

Approach the exposure device while observing the survey meter – observe the **GREEN MARKING** on the lock slide and survey the exposure device. The survey meter should indicate the same radiation level as observed before the exposure. Note particularly the outlet port reading.

Survey the entire length of source guide tube (and collimator or J-tube if used) with the survey meter. If the meter shows a sharp increase, the source assembly is exposed or incompletely shielded.

If the source is still exposed, attempt to store it properly by cranking the source a short distance towards the exposure head and retracting it, repeating if necessary.

Review the mandatory radiological safety requirements in the "Warnings" section if low-energy Yb-169 or low-activity Ir-192, Se-75 or Co-60 sources are being used.

### Locking the Exposure Device

When the source assembly is properly stored in the projector, rotate the selector ring from the OPERATE position to the LOCK position and secure it with the plunger lock.

Remove and safeguard the key.

### WARNING!

If after several attempts to return the source assembly, the selector ring cannot be rotated to the lock position (do not use excessive force) or the lock slide is not actuated, one must suspect an accident in which the source assembly may have become disconnected or stuck outside the projector, giving rise to a very high radiation field. Treat the situation as an EMERGENCY.





## STEP 5

### Dismantling equipment

#### Remote control unit

Unlock the exposure device and then rotate the selector ring counter-clockwise from LOCK to CONNECT. The remote control connector will partially disengage from the exposure device's locking mechanism.

Completely disengage the remote controls from the exposure device by disengaging the control cable connector from the source assembly connector. Place the protective cover over the remote control's connecting plug assembly to exclude dirt and protect the control cable connector from damage. Roll the remote control conduits loosely for easier handling and transport.

Reinstall the locking mechanism's protective cover, hold in place and rotate the selector ring clockwise to the LOCK position. Push in the plunger lock and remove the key to lock the exposure device.

#### Source guide tubes

Remove the source guide tube attached to the exposure device outlet port by:

- 1 Rotating the spring-loaded outlet cover 60 degrees in a counter-clockwise direction.
- 2 Grasp the source guide tube fitting and rotate a quarter of a turn in a clockwise direction. This action will allow removal of the source guide tube from the outlet port.
- 3 Simultaneously pull and rotate the spring-loaded outlet port cover a quarter of a turn in a counter-clockwise direction.

Place the protective covers on the fittings of each source guide tube used to exclude dirt and protect the swaged fittings. Source guide tubes should be rolled up loosely for easier handling and transport.

#### Surveying

After installing the locking mechanism's protective cover and the outlet port cover, survey the entire circumference of the exposure device with the survey meter to ensure the source is fully shielded and properly secured. The survey should not measure more than 2 mSv/hr (200 mR/hr) on any surface of the exposure device and should indicate the same measurement as the initial survey.

#### Storage

Lock the exposure device and secure it in a clean dry storage area where it cannot be tampered with or removed by unauthorized personnel. Perform a storage survey on the surface of the exposure device to verify the dose rate is less than 2 mSv/hr (200 mR/hr) and record.

A radioactive material warning notice must be posted on the door or entrance of the storage area. The door or entrance must be locked to prevent access by unauthorized personnel.

### Introduction

The QSA Global, Inc. Model 880 Delta, Sigma, Elite, Omega and Atlas radiographic exposure devices provide innovation to the most widely used family of radiographic exposure devices utilized for on-site gamma radiography. The Model 880 Series exposure devices are portable, lightweight and permit use of several different isotopes commonly needed by the nondestructive testing community.

The Model 880 is primarily designed for use with Iridium-192 sources for radiographic inspection of steel and light alloys. Due to the advancements in radiographic inspection techniques, additional source assemblies for the Model 880 Series devices are available. See Section 1 – Technical Specifications, for a complete list of sources and accessory equipment designed for use with the Model 880 Series devices.

The USNRC and international regulations require routine inspections to ensure that industrial radiography equipment is operating safely and properly. Design of the Model 880 Series devices includes inherent safety features and quality construction to ensure the highest degree of quality, safety, reliability and durability.

Care should be taken to prevent radiological incidents that can occur from neglect, accidental damage, abuse and lack of inspection and maintenance.

The following instructions should be followed carefully to ensure safe and proper operation of this equipment.

### Operational Features

#### 1 Source Assembly

A sealed source containing the radioactive material is swaged (crimped) to one end of a flexible steel leader, commonly referred to as the source holder or pigtail. A stainless steel stop-ball and a stainless steel connector are swaged to the opposite end of the source holder. The stop-ball provides the means to secure the source assembly within the exposure device's locking mechanism. The source assembly connector provides the means to attach the control cable connector to enable remote projection and retraction of the source assembly. The source assembly connector and projector locking mechanism are designed so that the sealed source cannot be projected from the exposure device unless it has been properly coupled to the control cable connector and the remote control. (See figure 3.1)



#### **DANGER - IMPORTANT WARNING**

**The source assembly while in an unshielded position and the sealed source containing the radioactive material must NOT be handled under any circumstances. The unshielded source at close proximity can cause serious injury, sickness or death to anyone exposed to it even for a short duration.**

All specific model number source assemblies used in the Model 880 are designed and tested for use in accordance to ISO/ANSI and USNRC requirements.

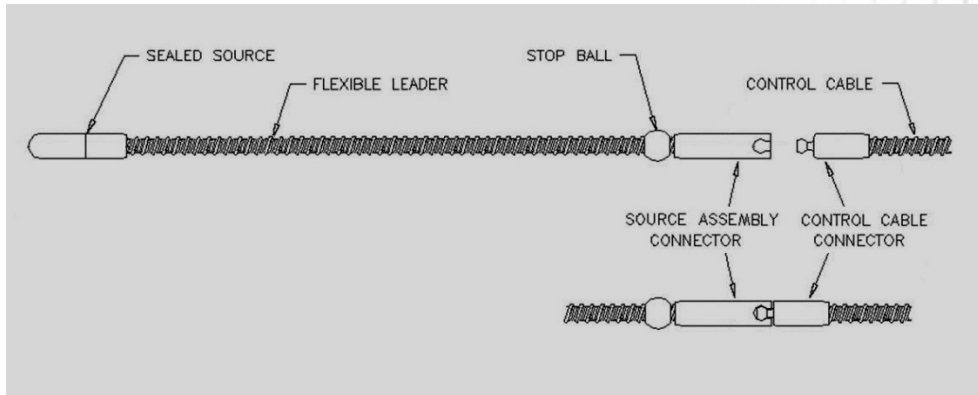

Figure 3.1 Source assembly and remote control cable connectors

## 2 Exposure Device

The source assembly is shown in the stored position in a titanium or 'S' tube at the center of the depleted Uranium shield of the exposure device. (See figure 3.2)

A remote control unit is shown with its control cable connector coupled to the source assembly.

High density depleted Uranium shielding is used in the exposure device to provide good radiological protection with minimal weight.

A shielded outlet port cover mechanism permits a secure attachment of source guide tubes (projection sheaths) without an elevation of radiation levels. The outlet port mechanism will not allow the source assembly to be projected outside of the exposure device unless a source guide tube has been properly attached to the outlet port. A three-step connection is accomplished by completion of the following steps:

- 1 Pull and rotate the spring-loaded outlet port cover a quarter turn (from a 12 o'clock to a 3 o'clock position) in a clockwise direction. This action moves the protective cover away from the outlet port to permit attachment of a source guide tube.
- 2 A bayonet-style fitting of the source guide tube is inserted into the outlet port and rotated a quarter turn (from a 12 o'clock position to a 9 o'clock position) counter-clockwise. A complete insertion and counter-clockwise rotation of the source guide tube fitting releases the lock and an internal shielding rotor of the outlet port.
- 3 Rotate the spring-loaded cover an additional 60 degrees (from a 3 o'clock position to a 5 o'clock position) in a clockwise direction until it stops. This last movement moves the outlet port shield out of position and aligns a pass-through opening on the rotor with the 'S' tube and outlet port while simultaneously securing the source guide tube fitting to the outlet port.

The design permits attachment of the source guide tubes without an elevation of radiation intensity at the outlet port, minimizing the radiation exposure to the radiographer's hands. The sealed source assembly cannot be exposed out of the exposure device unless a positive connection of the source guide to the device has been accomplished.

The exposure device's locking mechanism provides three main safety features for the radiographer during radiographic operations.

First, the locking mechanism requires a deliberate action to enable exposure of the source assembly. This is accomplished by coupling the control cable connector to the source assembly connector, coupling the remote control connector to the exposure device locking mechanism and then pushing a lock slide from the SECURED position into the EXPOSE position. The lock slide must be manually pushed into the EXPOSE position prior to each radiographic exposure to enable operation of the remote control.

Second, during termination of a radiographic exposure, the remote controls are used to retract the source back into the exposure device. When the source assembly is returned to the fully shielded position within the exposure device, the locking mechanism automatically secures the source assembly, preventing the source from being inadvertently exposed from the fully shielded position. The automatic securing mechanism allows movement of the exposure device with the remote controls attached at the job site while preventing inadvertent exposure of the source assembly.

For the third feature, the controls cannot be removed from the exposure device locking mechanism unless the source assembly has been returned to the fully shielded position within the exposure device.

The complete radiography system consists of the radiographic exposure device containing the source assembly, the remote controls, source guide tubes and collimators (beam limiters) whenever possible.

The use of multiple source guide tubes must be a combined length shorter than the length of the remote controls, e.g. if the remote controls are 25 ft (7.6 m) long, only 3 source guide tubes can be utilized for a combined length of 21 ft (6.4 m). This consideration ensures the source assembly will be fully projected to the source stop (exposure head).

The source assembly must never be projected until the equipment is properly connected and all personnel have exited the restricted area.

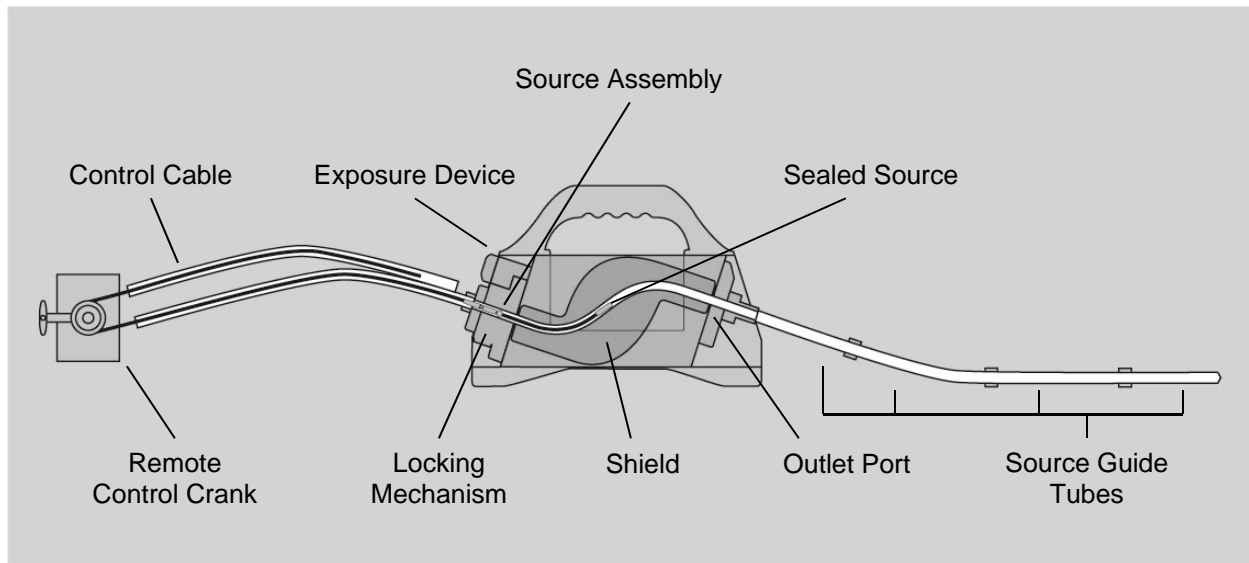

Figure 3.2 Sealed source in fully shielded position of radiographic exposure device.

### Transit Mode

Rotating the handle of the remote control crank in the EXPOSE direction (counter-clockwise) moves the source assembly out of the shielded position in the exposure device and into the source guide tubes (projection sheaths). (See figure 3.3)

The source assembly is under positive mechanical control using the remote control crank. The remote controls may be fitted with an odometer to provide an indication of the sealed source's position. The odometer reading should never be a substitute for the requirement and proper use of a radiation survey meter.

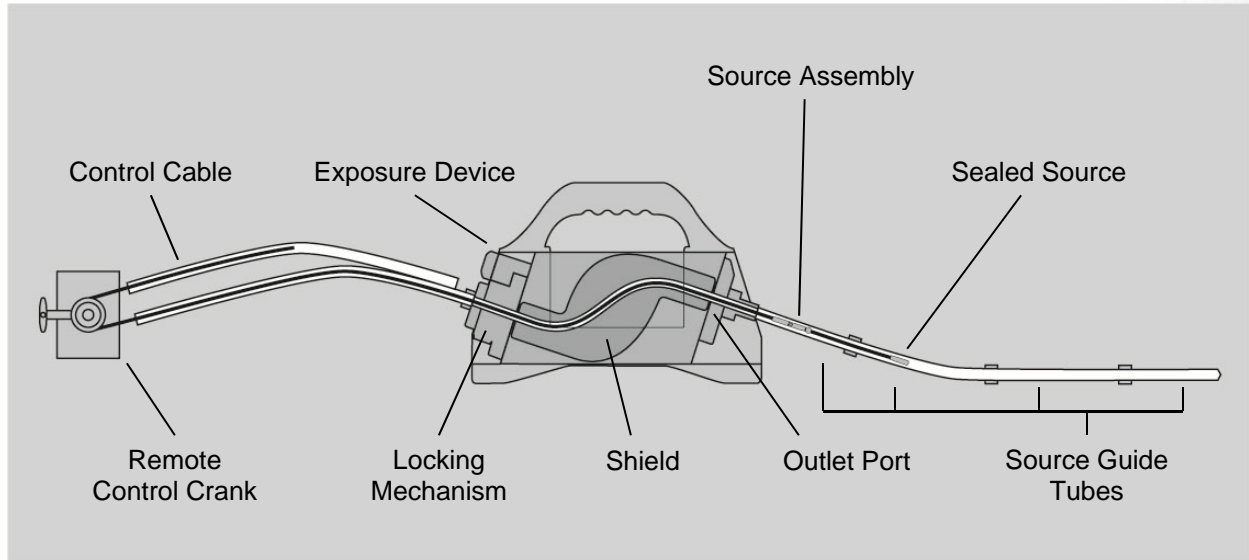

Figure 3.3 Sealed source in transit mode

### Exposure Mode

When the source assembly reaches the exposure head at the radiographic working position, the odometer will indicate (in feet and tenths of a foot) the approximate distance the sealed source has traveled. (See figure 3.4)

To return the source assembly to the exposure device the crank handle is rotated in the RETRACT direction (clockwise). When the source assembly is returned to the fully shielded position within the exposure device, the locking mechanism automatically secures the source assembly. The automatic securing mechanism will not permit exposure of the source assembly unless the radiographer pushes the lock slide into the expose position.

The remote controls cannot be disconnected from the source assembly unless the source assembly is fully retracted into the shielded position in the exposure device.

The system is designed for safe and reliable operation provided the system is properly used and maintained.

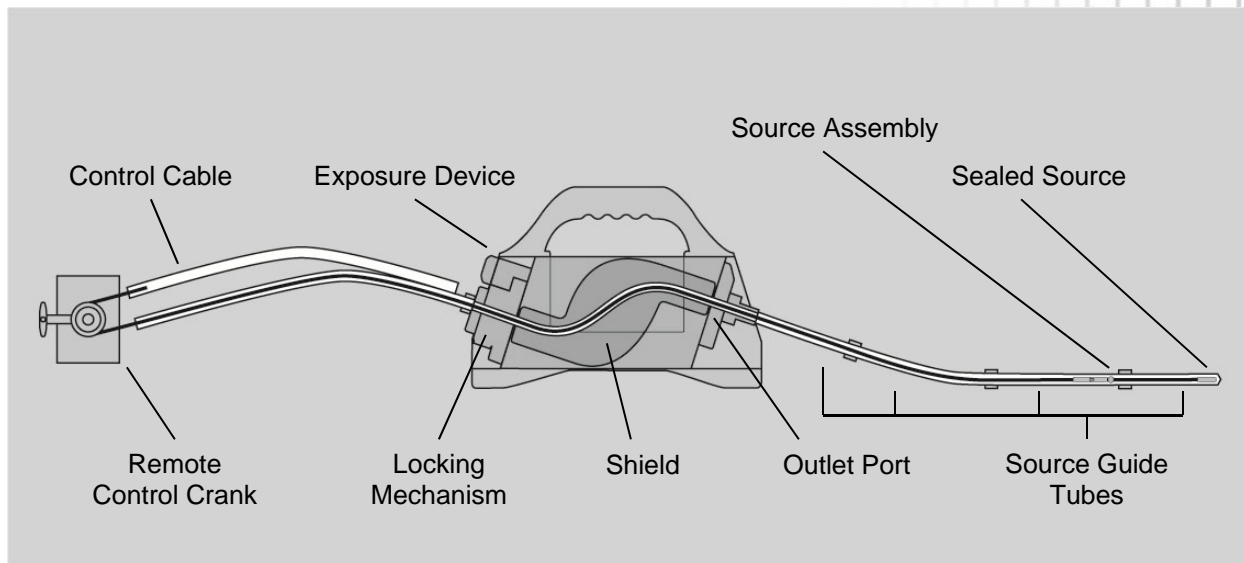

Figure 3.4 Sealed source in the exposure mode

### Daily Inspection of the System

A daily inspection of the gamma radiography system for obvious defects is essential to ensure the equipment is in a safe and proper operating condition. It is important that all radiographers perform or supervise this inspection prior to the first radiographic exposure of the shift regardless of any previous inspections that may have been performed that day. As an example, damage to a component of the system may occur during transport of the equipment to the job-site. If damaged equipment were used without detection, the result may be the inability to retract the source assembly into the exposure device and secure it.

The results of a daily inspection should be recorded and include the date, the name of the inspector and what specific equipment was inspected. If any defective or damaged components are discovered during the daily inspection, the component must be removed from service and identified with a status indicator (tag, label, or tape) to prevent inadvertent use by other radiography personnel. Defective or damaged components must be repaired or replaced before reuse in radiographic operations. The three main components of the radiography system consisting of the radiographic exposure device and transport case, remote controls and source guide tubes must be inspected in addition to accessories such as lab stands, collimators, J-tubes, magnetic lab-stands and pipe-clamping apparatus.

Radiographers must take a proactive role in preventing incidents, by performing or directly supervising a simple, but thorough daily inspection of the radiography system. The implications that affect safety and the importance of the daily inspection must be emphasized and understood by the entire radiography staff.

### Daily Inspection of the Exposure Device

- 1 Survey the surface of the exposure device or device in the transport case to ensure the radiation level is less than 2 mSv/hr (200 mR/hr), even when containing a source assembly with the maximum allowable activity. This survey provides a function check of the survey instrument that it is responding to radiation, in addition to providing the radiographer with a reference measurement that can be compared to confirmatory surveys after terminating each radiographic exposure.

- 2 Inspect the labels on the exposure device or the transport case to ensure they are legible and securely attached to the unit. The warning label containing the trefoil should be legible from a distance of at least 3 ft (approximately 1 m). This label warns the individuals in the immediate vicinity of the presence of radioactive materials and permits them to take measures to minimize their exposure to radiation. The printed verbiage and the radiation symbol must be legible. The trefoil symbol becomes the warning for those individuals who cannot read or understand the written warning, 'Caution or Danger, Radioactive Material'. Inspect the legibility and attachment of the source identification tag that describes the radioactive source contained within the exposure device.
- 3 Inspect the exposure device's locking mechanism to ensure the protective covers are installed over the source assembly connector. Inspect the plunger lock to ensure the lock will engage when the plunger is depressed and the key is removed. Grasp the entire locking mechanism with one hand and try to move the lock to determine that the screws have not loosened due to vibration. Unlock the plunger lock and remove the protective cover. Push the protective cover into the plunger lock housing for storage during use of the device.
- 4 Inspect the outlet port for damage and for smooth operation by operating the outlet port cover. Verify that the outlet port cover rotates smoothly and that the mechanism is not clogged with dirt, grease or sludge.

### Daily Inspection of the Source Guide Tube(s)

- 1 Remove the protective covers from the swaged fittings on the source guide tubes. Inspect both swage fittings to ensure the threads are not stripped or clogged with dirt, grease or sludge. Inspect the ears on the bayonet fitting to ensure they are not bent, broken or excessively worn. Inspect the three piece design bayonet to verify the separation gap is not excessively wide. (This indicates the screw-on portion may have loosened and should be serviced). Verify the bayonet adaptor rotates freely between the female fitting and the fixed bayonet section.
- 2 Inspect each length of source guide tube(s) that will be used for cuts, inward dents and heat damage. The inspection is primarily a visual one, but it should include the radiographer using his hands to feel for the inward dents. This is necessary due to the fact the outer material of the source guide tube is a flexible waterproof material that can mask dents. During a visual-only inspection, a dent in the source guide tube may retain a circular appearance on the exterior, while having an inward dent in the metallic conduit directly below the waterproof material. This type of masked dent can be felt by the radiographer's hands. Dents in the source guide tubes are the major cause of source hang-ups.
- 3 Inspect the source stop (exposure head) to ensure there is no excessive wear, perforations, bends and inward dents. Perform this visual inspection with the collimator removed from the source stop.



Inspect the collimator and the attachment of the collimator to the source stop (exposure head) if used during radiography. Verify the original equipment brass thumb-screw is being used. The use of generic set-screws other than original equipment may damage the source stop. Typical damage may include; scoring as a result of rotating the collimator around the source stop during radiographic set-ups and inward dents on as a result of over tightened steel set-screws.

- 4 Inspect the attachment of the collimator to the source stop (exposure head) if used during radiography. If collimator utilizes a thumb-screw to affix the collimator to the source stop, hand tighten only. The use of tools may damage the source stop.

### Daily Inspection of the Remote Controls

The remote control consists of a control crank, a control cable with a connector swaged at one end, two control cable conduits and a connector plug assembly.

The control crank contains a diagonally cut, geared drive wheel that matches the outer helical winding of the control cable. This worm-gear arrangement of the control crank drive wheel and the control cable provides the radiographer with a reliable means to project and retract the source assembly from and to the exposure device. The control crank is equipped with a lever brake that retains the source assembly while in the exposure head. Beneath the control crank is a label that indicates the direction for EXPOSE and RETRACT during use in addition to ON and OFF positions for the brake. Control cranks are available with an odometer to provide the radiographer with the approximate travel distance of the source assembly. The travel distance is indicated in increments of feet and tenths of a foot. Radiographers can count the number of rotations of the crank handle when using control cranks that are not equipped with odometers to obtain an approximation of the travel distance. One full revolution of the crank handle is equal to approximately 10 in (25.4 cm) of travel.

Two remote control conduits (sheaths, housings) are attached to the control crank. One conduit contains the working side of the control cable that drives the source assembly out of the exposure device and through the source guide tubes. The second conduit is the reserve conduit containing the length of the control cable necessary for projection of the source assembly. The remote control conduits provide a degree of protection of the control cable against the elements common to the working environments that industrial radiography is performed.

Attached to the opposite end of the remote control conduits is a connecting plug assembly that is used for attachment of the remote controls to the locking mechanism of the exposure device. The connecting plug assembly and the control cable connector are designed with minimal tolerances. A connection of the source assembly connector to the control cable connector must be completed before the remote control connecting plug assembly can be attached to the locking mechanism of the exposure device. A protective end-cover must be installed after use of the remote controls. The protective cover provides protection to the connecting plug assembly and the control cable connector and prevents the ingress of water, mud, sand or other foreign matter.



### IMPORTANT WARNING

**The control cable connector is a made from hardened steel and should never be left unprotected or forced into connection with the source assembly as this could damage the connector over time leading to possible breakage during use. Always use the protective end-cover when remote controls are not connected to the exposure device and always manually move the sleeve of the female connector of the source assembly to the OPEN position when connecting and disconnecting the control cable from the source assembly.**

The control cable (drive cable) is a flexible, steel cable with an outer helical winding. The length of control cable is approximately twice the length of the remote controls. Attached to one end of the control cable is a male connector. The control cable when used in conjunction with the remote control as a system provides a positive mechanical control of the source assembly at a distance. The control cable is a critical



link for safe operation and is the radiographer's only means of control over the source assembly. Therefore, the control cable's storage, use, daily inspection and quarterly maintenance are critical elements to the prevention of a control cable failure. In almost all cases, repairs for a control cable are not possible, with the exception of replacing the control cable's Model 550 male connector every five years. Damaged, defective or control cables with unknown origin (non-traceable) must not be used and must be removed from service.

### 1 Remote Control Inspection:

- a. Uncoil the remote controls at the site. Inspect the control crank to assure all screws are present and tightened and that the crank handle is properly secured. If the control crank is equipped with an odometer, zero the odometer while the control cable is fully retracted. Verify the odometer is fully functional.
- b. Ensure the instructions on the control crank's label are legible. These instructions are important to safety, especially when assistants are being trained or during an emergency. Without the instructions it is conceivable a radiographer could become confused as to which direction the crank handle must be turned to retract or expose the source.
- c. Ensure the brake is operational. Resistance should be felt while rotating the crank handle with the brake in the ON position. Inspect the control conduit fittings to verify they are secured to the control crank.

### 2 Control Conduit Inspection:

- a. Inspect the control conduit where it is swaged onto the fittings that mount on the control crank. There should be no evidence of cracks or breaks in the PVC sheath. Also, look for bulges in that area that result from repeated flexing.
- b. Visually inspect the entire length of both control conduits looking for dents, cuts and thermally damaged areas. During this inspection, the radiographer should use his hands to feel for inward dents. Cuts and melted areas found on the control conduits should be sealed with PVC tape to prevent against the ingress of water.
- c. Inspect the control conduits where they are swaged to the swage fittings that are mounted to the connecting plug assembly. There should be no evidence of cracks, breaks or bulges in the PVC sheath.
- d. Remove the protective cover from the connecting plug assembly. Inspect the connecting plug assembly to verify the movable jaws are not excessively loose and the connecting collar pins are not excessively loose or bent. Check the control sheath swage fittings to verify they are not loose where they are joined to the connecting plug assembly.

### 3 Control Cable Inspection:

- a. Inspect the control cable connector as it protrudes out of the connecting plug assembly. The control cable connector should not be bent or at an angle exceeding 15 degrees relative to the control cable centerline. If a control cable connector is repeatedly bent at an angle greater than 15 degrees, damage to the control cable may be introduced by straightening the bend. Inspect the control cable (male) connector to verify that the stem and ball of the connector are not bent or cracked. Using hand pressure, attempt to twist the control cable connector from the control cable. If the control cable connector can be twisted using hand pressure or appears bent or cracked, remove from service and label as defective.

- b. Pull approximately 12 in (30.5 cm) of control cable out of the connecting plug assembly and inspect for the following anomalies directly behind the connector:
- Cuts, breaks, nicks or fraying of the spiral windings of the control cable.
  - Areas with kinks or permanent bends.
  - Rust (a red oxide) on the inner core of the control cable.
  - Uniformity of the spacing between the outer spiral windings. Also check for flattened areas and wear.
  - Bend the connector section of control cable back towards itself and release the cable to test for flexibility or 'spring' of the control cable. A cable that has been subjected to the flexibility test and remains in the bent position after the test provides an indication of internal corrosion and **must be removed from service**.
  - Verify that a light coating of mil-spec grease is present on the control cable. The light coating of grease is necessary to prevent the penetration of water and chemicals that can oxidize and permanently damage the control cable.
- c. Check for freedom of movement of the control cable within the remote controls by moving the control crank handle back and forth approximately one-quarter turn. During this test, take care to avoid cranking the control cable onto the ground exposing it to dirt and sand. If any resistance is felt during this check, re-inspect the control conduits for dents or depressions. If dents are not present on the remote control conduits, the control cable may be rusted stiff somewhere within the control conduits. Do not use remote controls that do not function properly or exhibit defects described above.
- d. A final check of the control cable connector and source assembly connector is accomplished by use of a Model 550 NO GO gauge to check for significant wear on the connectors that would affect safety. Without using excessive force, check the following four positions (see figure 3.5):
- 1 Ball at the end of the control cable connector must NOT GO into the hole of the gauge.
  - 2 The shank or stem of the control cable connector must NOT GO into the smaller of the two notches located on the side of the gauge.
  - 3 The width of the gauge must NOT GO into the female slot of the source assembly connector.
  - 4 After a positive connection between the control cable and source assembly connectors has been accomplished, verify that the larger notch located on the side of the gauge will NOT GO in the gap between the joined connectors.

**Replace any components that fail any of the NO GO gauge tests, because a failure indicates significant wear that could allow safety features of the design to be defeated.**

### **IMPORTANT REMINDER**

**Do not compromise on safety. Always perform a daily inspection of the exposure device, projection sheaths and remote controls prior to use.**

**Defective equipment that is discovered during the daily inspection must be removed from service until repaired or replaced.**

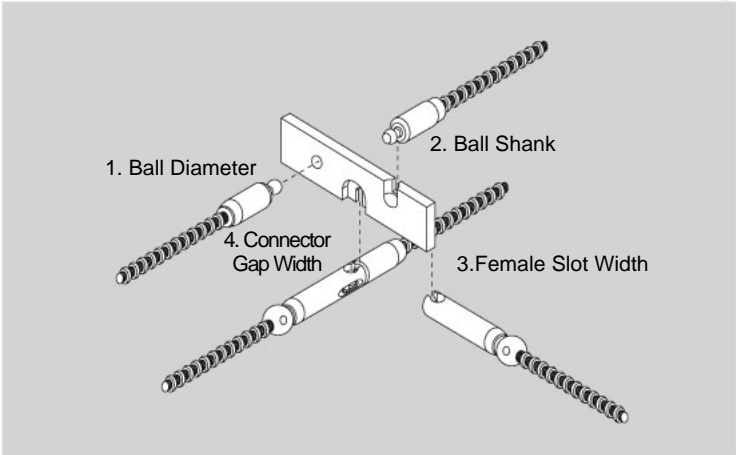

**Figure 3.5 No-Go gauge tests**

### **Quarterly (Routine) and Annual (Complete) Maintenance Requirements**

Radiographic exposure devices and associated equipment must be maintained regularly by trained and qualified personnel to ensure consistent and safe operation of the radiographic system. The routine inspection and maintenance also ensures that the integrity of the Type B(U)-96 and Type A transport packages are maintained in compliance with the package certification numbers; USA/9296/B(U)-96, CDN/E199/-96 and approval requirements, respectively.

Manufacturers base the recommended inspection and maintenance requirements on the system's design, application, materials, anticipated work cycles, environmental factors of use under the normal and abnormal conditions of industrial radiography and while in the transport system. A program of systematic maintenance will prolong the working life of the radiographic exposure device and associated equipment in addition to ensuring safety during use. By most national regulations, routine maintenance of the systems is required at intervals not to exceed 3 months in addition to the radiographer's daily inspections for obvious defects. The complete annual servicing ensures the integrity of the system.

Maintenance program administrators must recognize the need for maintenance intervals that are less than the required 3-month interval especially in cases where the systems are used in severe environmental conditions. Maintenance program administrators must ensure the systems are completely serviced immediately after certain jobs in severe conditions. Extreme or severe conditions may include, but is not limited to conditions where the equipment was:

- Immersed in water or mud.
- Subjected to high-concentrations of particulate such as fly ash, sand or foundry green-sand.
- Subjected to hot radiography conditions.
- Subjected to salt-water conditions, caustic or acidic materials.
- Subjected to accidental drops or falling objects.
- Whenever subjected to extreme environmental conditions.

The routine maintenance performed every 3 months requires partial disassembly, cleaning, inspection, re-lubrication and operational checks of the system. The complete maintenance (performed once a year) involves a complete disassembly, cleaning, inspection, re-lubrication and operational tests of the entire system.

Trained and qualified individuals within the licensee's organization can perform equipment maintenance. QSA Global, Inc. service engineers are available to provide maintenance on the systems at the licensee's premises or at one of the service centers.

## Routine (Quarterly) Maintenance Requirements

### 1 Remote Controls

Disassemble, clean, inspect and maintain the remote control crank, control conduits and control cable according to the complete service section. Record the results of the inspection and any repairs that are performed. Any components found to be deficient during the inspection must be removed from service until repaired or replaced. Deficient components must be labeled with a status indicator to prevent inadvertent use.

### 2 Source Guide Tubes

Clean and inspect the source guide tubes in accordance to the “Quarterly and annual maintenance for source guide tubes” section of this manual. Record the results of the inspection and any repairs that are performed. All source guide tubes found to be deficient during this inspection must be removed from service and sent to a service center for repairs. Deficient components must be tagged with a status indicator to prevent inadvertent use.

### 3 Radiographic Exposure Device

Clean and inspect the exposure device/transport container for wear and obvious damage. Record any defects that might affect safe operation of the exposure device or contribute to unsafe transport of the device in the container. If deficiencies are found during this maintenance, the exposure device must be removed from service until repairs are accomplished and the results of subsequent operational tests and inspection are satisfactory. Inspect the radiography system for the following using a ‘satisfactory’ or ‘deficient’ criteria:

- a. Survey the surface of the container to ensure the measurable dose/rate is less than 2 mSv/hr (200 mR/hr) and less than 20  $\mu$ Sv/hr (2 mR/hr) at 1 meter (to comply with ANSI/ISO requirements). Remove the device from service if the dose/rate exceeds these limits. Contact QSA Global, Inc. for guidance.
- b. Ensure the metal identification tags for the radioisotope is legible and securely fastened to the exposure device. Do not cover the tag with any other labels.
- c. Ensure the label containing the device model number, serial number, Type B(U) certification number (or Type A specification identification) and the trefoil with the warning ‘Caution or Danger, Radioactive Material’ is legible from a distance of 3 ft (approximately 1 m) and securely fastened to the container. Do not cover the required warnings with any other labels. Ensure the labels applied for transportation are legible.
- d. Check the welded stainless steel end plates of the exposure device for weld failure (cracks, etc.) behind the back plate (locking mechanism) or the front plate (outlet port). Ensure the handle, the bottom contact surfaces and the sides comprising the plastic jacket of the exposure device are intact. Check the bottom contact surfaces of the jacket to ensure the contact area is not excessively worn allowing contact of the stainless steel body with the work surface. If any deficiencies are found during this inspection, repairs can be accomplished at a QSA Global service center.
- e. Check the outlet port for proper function by attaching and removing a source guide tube. The operation should be smooth and resistance free. If there is any resistance or ‘crunchy’ feeling noticed during attachment or removal of the source guide tube or during movement of the outlet port cover, this indicates excessive amounts of sand or dirt within the mechanism. The outlet port mechanism must be removed, cleaned and lubricated according to the complete service instructions.

- f. Check the locking mechanism and plunger lock to verify attachment and operation. Grasp the entire mechanism with one hand and attempt to shift the mechanism. Retaining screws that have been loosened from excessive vibration or improper maintenance will allow the movement of the locking mechanism during this check. Loose screws must be tightened according to the annual maintenance requirements prior to use or transport.
- g. Use the Model 550 NO GO gauge to check for wear on the remote control cable connector and the source assembly connector. Replace components that fail any of these tests.
- h. Operationally check the locking mechanism and then the function of the entire system during the first radiographic exposure of the work shift while within a restricted area. Operation of the radiographic system verifies both the locking mechanism and entire system operates smoothly and freely. If operation is faulty, remove the exposure device from service and perform the complete annual maintenance.

### Misconnect Test

After performing the quarterly maintenance, the complete radiography system must be tested by the maintenance program administrator or Radiation Safety Officer. A misconnect test on the exposure device including the radioactive source assembly and remote controls effectively tests the integrity of the entire locking system. This procedure detects long-term wear (or damage) of the interrelated failsafe system including identification of any excess wear on the safety connector assembly, the drive cable connector, the exposure device automatic securing mechanism and the source assembly connectors simultaneously.

**Note: Component wear occurs to both the control assemblies and the device locking mechanisms over time, therefore, to ensure acceptable equipment operation, the misconnect test must be performed on each device lock assembly and control assembly that will be used for radiographic operations. All remote controls must be tested using a QSA Global, Inc. manufactured automatic securing mechanisms equipped with a QSA Global, Inc. manufactured source assembly, 550 jumper or A424-9XL mock source assembly to ensure the effectiveness of the misconnect test.**



### WARNING

The test should only be performed by personnel that are formally trained, authorized and thoroughly familiar with annual maintenance procedures. This test is performed by engaging the remote control connecting plug assembly into the exposure device's locking mechanism **WITHOUT** first engaging the control cable connector within the source assembly connector.

The ability to then rotate the locking mechanism from the CONNECT position towards the LOCK position indicates critical dimensions of the locking system are excessively worn to an unsafe condition. **Extreme care should be exercised to prevent rotating the locking mechanism's selector ring beyond the LOCK position (see WARNING above).** If the locking mechanism and remote controls fail a misconnect test the equipment must be removed from radiographic operations. The equipment must not be used until repairs are performed and misconnect test results are satisfactory.

During the performance of the misconnect test there is a **risk of losing control of the radioactive source assembly if:**

- the components are excessively worn or damaged
- the person performing the test intentionally or inadvertently rotates the selector ring from the CONNECT position to the OPERATE position
- the person performing the test intentionally or inadvertently pushes the lock slide into the EXPOSURE mode.

Contact a QSA Global, Inc. service center if you have questions regarding the misconnect test.

### **Routine (Quarterly) Maintenance Records**

Records of all equipment inspected and maintained during the routine maintenance must be recorded. Records should indicate:

- The date of inspection and maintenance.
- Name and signature of the qualified individual performing the required inspections.
- Problems found and maintenance or repairs performed.
- Model number and serial number of the exposure device and transport container.
- Associated equipment that was inspected and maintained.
- Part numbers and associated lot numbers or serial numbers of replacement parts installed.

### Annual Maintenance Requirements

Radiographic exposure devices used under normal environmental conditions should only require complete maintenance once a year. Complete maintenance on the associated equipment including the remote controls and source guide tubes should be performed every three months to detect deficiencies and to prevent corrosion and wear related problems.

The complete maintenance of the exposure device requires the disassembly of the exposure device to enable a detailed inspection of all major components. Therefore, the inspection and maintenance requires transfer of the source assembly from the exposure device into a source changer performed inside of a restricted area. The annual inspection and maintenance must be performed by individuals specifically trained, qualified and authorized for this work.

Perform the following steps to transfer the sealed source from the exposure device into a source changer:

- 1** Perform a survey of the exposure device to ensure measurable dose rates are less than 2 mSv/hr (200 mR/hr) and less than 20  $\mu$ Sv/hr (2 mR/hr) at 1 meter (to comply with ANSI/ISO requirements) when loaded to maximum capacity. Perform a radiation survey and an inspection of the source changer to be used according to the source changer's operating instructions manual.
- 2** Perform a daily inspection of the remote controls, source guide tube and exposure device according to the daily inspection section of this manual. If the source assembly connector fails the NO GO gauge test, do not proceed with transfer of the source assembly. Contact a QSA Global, Inc. service center for advice on disposition of the source assembly.

Use the Model 550 NO GO gauge to check the remote control cable connector before and after a connection to the source assembly connector. For complete instructions to use the NO GO gauge and points tested (review the daily inspection instructions).

Do not use remote controls that do not meet the inspection criteria described in the daily inspection.

- 3** Set up the equipment within a restricted area before transferring the source assembly into the source changer according to the instructions supplied with the source changer. The transfer must be performed by properly trained and licensed personnel. Use a survey meter to perform confirmatory surveys of the exposure device, source guide tube and source changer to confirm that the sealed source is properly secured. Engage the lock on the source changer to lock the sealed source within the source changer.

Remove the source identification tag from the exposure device and fasten it to the source changer.

Attach a Model 550 connector gauge (jumper) to the end of the remote control cable connector found inside of the protective cover of the locking mechanism. The jumper will allow removal of the remote controls from the locking mechanism of the device after the remote control cable connector is returned to the exposure device lock.



## Leak Testing

### Leak Test of the Radioactive Sealed Source

Periodic leak tests of the radioactive sealed source are required by most national and international regulations. The leak test provides a confirmation of the integrity of the hermetically welded sealed source by determining the amount of removable contamination. In most regulatory jurisdictions, a leak test of a sealed source must be performed every 6 months or prior to its first use after removal from storage. Acceptable results of a radio-assay must indicate removable contamination is less than <185 Bq (0.005  $\mu$ Ci). To perform a wipe of the radioactive sealed source, perform the following steps:

- 1 Survey the entire exterior surface of the exposure device to ensure the dose/rates are less than 2 mSv/hr (200 mR/hr).
- 2 Prepare a Model 518 wipe test swab according to the instruction sheet. Fill in all required information for the source on the leak test form. Omission of the isotope, source model and serial number, etc. will delay processing of the wipe test.
- 3 Install service bayonet fitting (part no. 88049) into the outlet port and rotate the cover to allow the wipe test wand to enter the 'S' tube.
- 4 Fully insert the wipe test swab into the 'S' tube and move back and forth to obtain the sample.
- 5 Carefully withdraw the wipe test swab from the outlet port while observing the survey instrument. Withdraw the plastic bag over the wipe test wand without touching. Always assume the sample is contaminated.
- 6 Remove the service bayonet fitting from the outlet port and rotate the outlet port cover into the closed position.
- 7 In a low background (no radiation) area, switch the survey meter to the lowest scale and obtain a background measurement. Leaving the survey meter stationary, move the plastic wrapped swab towards the survey meter's detector to determine if a gross quantity of contamination is on the wipe test. If the survey meter measures greater than 1  $\mu$ Sv/hr (0.1 mR/hr), contact QSA Global, Inc. for instructions. If there is no measurable increase above background, the sample may be sent to the SENTINEL™ laboratory for radio-assay. The SENTINEL™ laboratory will send a leak test certificate after performing the radio-assay. Retain this certificate in your records.

In the event you are informed by the radio-assay laboratory that your leak test results indicate greater than >185 Bq (0.005  $\mu$ Ci), you must immediately remove from service the radioactive sealed source, the exposure device and all remote controls, source guide tubes, collimators, lab stands, etc. that were used in conjunction with that sealed source. You must cause the equipment to be repaired or decontaminated and notify the regulatory agency (USA) within 5 days (check local regulations for reporting requirements). Contact the sealed source manufacturer for assistance.

### Leak Test for Depleted Uranium (DU)

Some regulatory jurisdictions require periodic leak tests every twelve months of all projection-type exposure devices that utilize DU for shielding. The purpose of the leak test is to detect the long-term wear through of the device's source tube that may consequently expose the DU shielding. A wipe-test wand that is both flexible and long enough to reach a bend radius or a wear point is required to perform a leak test. The wand enables direct contact with the DU where the device's source tube has worn through. A direct wipe of the DU is required due to the low specific activity of depleted uranium. The wipe test for DU is obtained in the same fashion as a leak test of a sealed source utilizing the same radiation safety procedures.

The analysis performed on the wipe test must be capable of detecting the presence of 0.005  $\mu\text{Ci}$  (185 Bq) of radioactive material on the test sample. If the test sample reveals 185 Bq (0.005  $\mu\text{Ci}$ ) or more of removable DU contamination, the exposure device must be removed from service until an evaluation of the wear on the 'S' tube has been made. Should the evaluation reveal that the source tube is worn through, the exposure device may not be used again.

DU shielded devices do not have to be tested for DU contamination while in storage and not in use. Before using or transferring a device that has been in storage for more than 12 months, the exposure device must be leak tested for DU contamination prior to use or transfer. Please contact a QSA Global, Inc. service center if you require leak test kits, radio-assay services or assistance in the disposal of worn through exposure devices.

### Annual Maintenance for the Model 880 Series Exposure Devices

Tools required for complete maintenance

- 5/32 in Allen wrench for the 10-32 socket head lock and selector-ring screws.
- 3/32 in Allen wrench for the lock's socket head screw.
- Number 30 Drill bit and pop-rivet gun for removal and installation of 1/8 in s/s rivets.
- Tamperproof tool bit for locking mechanism plate screws.
- Calibrated torque wrench (in/lb) for locking mechanism's socket head screws.
- Small slot screwdriver for source identification tag 6-32 screws.
- U-tool (part # SK1761) for functional checks of lock mechanism.
- Model A424-9XL mock source assembly and short length control cable for lock mechanism operational tests after servicing.

Materials required for Model 880 Series complete maintenance:

- Mil-spec grease MIL-G-23827B (or C), MIL-PRF-23827C, (or equivalent radiation resistant grease authorized by QSA Global, Inc.).
- Temporary Lock-tite™ 242 or Vibra-tite™ thread sealant.
- Recommended solvents for cleaning and degreasing operations: clean mineral spirits (Follow manufacturer's safety precautions for use, handling, storage and disposal).
- Clean lint-free rags.
- 12-gauge gun patches or any lint-free cloth for cleaning the 'S' tube.
- Large pan for use in cleaning and degreasing the remote drive cable and mechanical parts.
- Stainless steel, brass or synthetic bristle brush to be used during degreasing and cleaning of parts.
- Light viscosity oil, such as 3-in-1™ oil to lubricate plunger lock.
- Model 880 label if required and (4) each 1/8 in stainless steel rivets.
- Lock mount rubber sleeves (4) each.
- Permatex™ anti-seize thread lubricant.
- Replacement springs for the locking mechanism –
  - 1 x compression spring part number SPR006
  - 1 x compression spring part number SPR005
  - 2 x compression spring part number SPR004
- Replacement springs for the outlet port – 2 x compression spring part number SPR033.
- Bayonet-type source guide tube for operational tests of the outlet port.

### Model 880 Series Annual Maintenance Requirements

Model 880 Series exposure devices must receive inspection and maintenance at least once a year.

The locking mechanism and outlet port mechanism must be removed from the exposure device and disassembled for proper cleaning, inspection and lubrication of components that are critical to safety.

These procedures can only be performed on an empty exposure device, which requires transfer of the radioactive source assembly into an approved storage container.

The inspection and maintenance procedures must be performed by personnel specifically trained and qualified for this work. QSA Global, Inc. service engineers will service these systems at one of their service centers or in the field upon request.

Trained and qualified personnel who wish to perform this work should use the following procedure:

- 1 Perform a daily inspection of the system and transfer the radioactive source assembly into an approved storage container. Disengage remote controls and source guide tubes. The exposure device must be empty for the following steps.
- 2 Remove the four 5/16-18 x 1½ in socket button-head screws that retain the locking mechanism plate from the empty Model 880 device using the tamperproof tool bit mounted in a ratchet.
- 3 Remove the 10-32 socket head screws that retain the selector-ring and plunger lock housings from the mounting plate using a 5/32 in Allen wrench.
- 4 Disassemble the locking mechanism assembly, taking care not to lose the spring loaded parts. Place the disassembled locking mechanism components into a pan filled with fresh, clean solvent. Clean all parts using a brush to dislodge any dirt or grease. Remove cleaned parts from the solvent bath, dry and place on a clean surface. Inspect all parts for wear. Replace worn parts as necessary.

Discard all used locking mechanism springs and replace with new springs. All compression springs located within the selector ring mechanism must be replaced at 12-month intervals to ensure smooth and consistent operation of the mechanism.

When ordering spare parts, quote the model and serial number of the exposure device as well as the part number to ensure correct replacement.

Remove the lock retainer from the mounting plate by unscrewing the two 10-32 x ½ in socket head screws using a 5/32 in Allen wrench. Remove the plunger lock from the lock retainer by removing the cap screw using a 3/32 in Allen wrench. Clean the lock plunger, lock retainer and springs in a solvent bath. Ensure the lock plunger is thoroughly rinsed to remove all dust from the key tumblers. Remove the cleaned parts from the solvent bath and dry thoroughly, using compressed air to dry the lock tumbler. Inspect all parts for wear. Replace worn parts as necessary. Lubricate the plunger lock barrel and tumbler using two drops of light viscosity oil. Apply Vibratite™ thread sealant to the lock set screw and install. Check the plunger lock for proper function by using the key to engage and unlock. Apply Vibratite™ to the lock retainer's 10-32 x ½ in screws, then mount the lock retainer to the locking mechanism plate. Hand-tighten the screws using a 5/32 in Allen wrench.

Apply a light coating of lubrication to the inside surfaces of the selector body and selector ring using MIL-G-23827B (or C), MIL-PRF-23827C, (or equivalent radiation resistant grease authorized by QSA Global, Inc.). Do not lubricate the lock slide and sleeve. Note that some types of greases may undergo chemical changes and form tars when exposed to radiation.

- 5 Begin assembly of the locking mechanism by lightly coating all components with MIL-G-23827B (or C), MIL-PRF-23827C, (or equivalent radiation resistant grease authorized by QSA Global, Inc.). Treat all screw thread ends with Vibratite™ or Loctite™ 242 thread sealant.

Mount the locking mechanism plate horizontally in a vise or fixture with the plunger lock and retainer at a 12 o'clock position. (Note: Carefully mount the mounting plate in a vise or fixture so hands are free for the assembly procedure and no damage to the mounting plate will occur.)

The narrow end of the lock slide slot must be located at the 3 o'clock position. Locate the lock slide and return spring into the mating slot of the selector body.

Place the selector ring with the word CONNECT at the 12 o'clock position, over the selector body. Push the lock slide inward during placement of the selector ring for clearance. Doing so will allow the selector ring to rest flush on the selector body. Insert the anti-rotation lug springs at the top and bottom of the selector body. Place the anti-rotation lugs over the springs.



Place the tungsten sleeve with the large diameter facing downward, on the center of the lock slide. Place the compression spring over the sleeve.

Install the selector ring retainer into the selector ring. Verify that the three non-threaded holes line up under the word CONNECT located on the selector ring. Depress the selector ring retainer into the selector ring until it is flush with the top of the selector ring. Hold the selector ring retainer firmly against the mounting plate until the 10-32 x 1¼ in screws are installed.

While firmly holding the locking mechanism against the mounting plate, turn the plate over to expose the back side of the mounting plate. Install the four 10-32 x 1¼ in socket head screws to secure the mechanism to the mounting plate. Torque the socket head screws to 30 in/lb (3.39 Nm) ± 5 in/lb (0.57 Nm) using a calibrated torque wrench.

**6** Perform functional safety testing of the automatic securing and locking mechanism by the following:

Mount the locking mechanism plate vertically in a vise or mounting fixture with the plunger lock at the 12 o'clock position.

Insert the 'U- tool' into the top and bottom holes of the selector assembly and rotate the selector ring toward the OPERATE position. Push the lock slide until the sleeve snaps into place.

While in the OPERATE position, wind out a short length of control cable and pass it through the front of the selector assembly. Attach a mock source assembly or the test jumper connector to the control cable connector and withdraw it into the selector assembly.

Pull on the section of control cable and confirm that the lock slide automatically secures the connector. The lock slide must snap shut in a fast and smooth motion when triggered. Verify the securement action of selector mechanism by attempting to both push and pull the mock source assembly out of the selector mechanism while in the EXPOSE, LOCK and CONNECT positions.

Rotate the selector mechanism back to the OPERATE position and push in the lock slide to ensure smooth operation and positive engagement. Attempt to push the lock slide towards the SECURED position to test for a positive engagement of the sleeve in the lock slide. If a smooth operation is not attained and/or the lock slide can be forced into the secured position by testing for positive engagement, disassemble and thoroughly re-inspect for faulty components.

Thoroughly inspect all components for rough edges or burrs, etc. which could cause jamming or irregular operation. Replace parts as necessary, re-lubricate and reassemble the selector assembly. Repeat the functional safety testing to verify smooth and safe operation of the selector mechanism. Do not install the serviced back plate (lock mechanism) module to the exposure device at this point.

**7** Remove the front plate containing the outlet port mechanism from the empty Model 880 device by removing the four 5/16-18 x 1½ in socket button-head screws using the tamperproof tool bit mounted in a ratchet.

After removing the outlet port mechanism, clean the 'S' tube of the exposure device by pushing cloth swabs wetted with solvent through the 'S' tube until they come out clean. Use a dry cloth swab to remove any residual solvent from the 'S' tube after cleaning.

Clean the exterior of the Model 880 using a mild detergent solution to remove all dirt and grime. Visually inspect the exposure device's stainless steel end plates for weld failures (cracks, etc.) on the locking mechanism and outlet port ends. Ensure the handle, the bottom contact surfaces and sides comprising the plastic jacket are intact. Check the bottom surfaces of the jacket to ensure the contact area is not excessively worn allowing contact of the stainless steel body with a flat work surface. Additionally, if dents to the device's body or flanges due to accidental drops are found during this inspection, these repairs must be performed at a QSA Global service center.

Ensure that all of the information contained on the Model 880 label is legible. The trefoil and the warning, 'Caution or Danger, Radioactive Material', must be legible at a distance of 3 ft (approximately 1 m). The model number, serial number and Type B certification number (or Type A Specification identification) must also be legible. For label replacement, remove the old label from the exposure device by using a number 30 drill-bit mounted in a hand drill. Remove the rivet heads used to fasten the label to the stainless steel body by drilling through the rivet head just enough to allow the rivet head to rotate freely. Remove all rivet heads to remove label. Install the replacement label and use a pop-rivet gun to secure the new 1/8 in x 3/16 in stainless steel rivets.

Disassemble the front plate (outlet port mechanism) by removing the set screw (or roll pin) from the outlet port cover. Unscrew the two socket head cap screws from the pivot disk. Remove and discard the two compression springs from the outlet port mechanism and replace with new springs.

Clean all parts in solvent using a brush to dislodge all dust and dirt. Dry all components thoroughly. Do not lubricate, leave all components completely dry.

Inspect for wear and burrs on the brass slider and rotor surfaces. Verify the tungsten port shield is not loose within the rotor. If the port shield is loose, remove the set screw, apply Vibratite™ thread sealant and retighten the set screw against the tungsten port shield. If the port shield uses a roll pin, remove the roll pin and replace. Inspect the front plate's outlet port for wear and burrs where the source guide tube bayonet fitting engages.

Install new compression springs and assemble the outlet port mechanism. Apply Vibratite™ thread sealant to the socket head cap screws before tightening. Install a new set screw to the outlet port cover.

After assembly of the front plate, perform the following safety function tests using a bayonet source guide tube fitting. Pull the outlet port cover and rotate clockwise 90 degrees. Movement should be smooth and limited to a clockwise 90 degree turn. Insert a bayonet fitting into the outlet port and rotate 90 degrees in a counter-clockwise direction. Insertion and rotation of the bayonet fitting should be smooth and without snags. Rotate the outlet port cover from a 3 o'clock position to a 5 o'clock position. This operation moves the rotor from the port shield position to a pass through section of the rotor. Reverse the operation to disengage the bayonet fitting. Repeat the function test three times to ensure smooth operation.

### **8** Re-assemble the Model 880 exposure device by performing the following steps:

Apply Permatex™ anti-seize thread lubricant to the first several end threads of the back plate's (locking mechanism) four 5/16-18 x 1½ in socket button-head screws. Align and attach the locking mechanism assembly to the exposure device's end plate by installing the four 5/16-18 x 1½ in screws using a tamperproof tool bit mounted in a calibrated torque wrench. Torque the tamperproof screws in an opposing cross pattern to 110 in/lbs (12.43 Nm), ± 5 in/lb (0.57 Nm).

Operationally test the function of the entire system using a bayonet-fitting source guide tube, the remote controls and a mock source assembly.

Attachment of the bayonet source guide tube to the outlet port must be smooth and without resistance. Rotate the outlet port mechanism to enable exposure of the mock source assembly.

Connect the (serviced) remote controls to the mock source assembly connector and the device locking mechanism. Push the lock slide into the EXPOSE position and crank the control cable into the exposure mode. While cranking the mock source assembly from the exposure device, carefully feel for resistance or snags. During retraction of the mock source assembly back into the exposure device, carefully feel for any resistance or snags during movement. Conclude the test by verifying the

lock slide automatically secures the mock source assembly. Action of the lock slide should be smooth with an audible 'snap' during automatic securing. After automatic securing, attempt to expose the mock source assembly from the exposure device to confirm a positive capture. Repeat this testing several times. If resistance, snags or sluggish movement of the lock slide is discovered during this testing, remove the outlet port and locking mechanism plates to determine the cause. Repeat all safety function tests if any additional servicing is required.

Clean the Model 550 jumper gauge in solvent. Lubricate the inner sleeve with light oil while moving the sleeve back and forth. Apply a light coat of oil over the entire jumper and insert back into the spring clip of the locking mechanism's protective cover.

### Annual Maintenance for the Remote Controls

Tools required for complete maintenance of Models 692, 693, 664 remote controls:

- 11/16 in open-end wrench for the control conduit swage fittings.
- 1/2 in open-end wrench for the 5/16 in control crank handle bolt.
- Slot screwdriver for the 10-32 remote control crank screws.
- 3/8 in wrench for the 10-32 control crank stop nuts.
- 0.050 in Allen wrench for the 4-40 set screw on the odometer knob on the Model 693 and Model 664 remote control units.
- Control cable run-off prevention (stop) spring removal tool if required.
- Model 550 connector NO GO gauge for wear check of the control cable connector.
- X4 to X7 magnification glass for control cable inspection if required.
- Micrometer for measurement of control cable diameter.

Materials required for complete maintenance of Models 692, 693, 664 remote controls:

- Clean solvent: fresh mineral spirits recommended for cleaning and degreasing remote control mechanism, control cable and cleaning the control conduits internally. (Follow manufacturer's safety precautions for use, handling, storage and disposal.)
- Large pan for cleaning and degreasing the control crank assembly and control cable.
- Clean lint-free rags and detergent to clean the exterior of the control conduits.
- Mil-spec grease, MIL-G-23827B (or C), MIL-PRF-23827C (or equivalent radiation resistant grease) for lubricating the control cable and control crank mechanism.
- Stainless steel, brass or synthetic bristle brush to clean control crank parts and the control cable.
- Compressed air source and hand nozzle to blow dry the control cable internal Teflon™ liner of the remote control conduits after cleaning.
- 3M™ yellow polyvinyl tape (or black polyvinyl electrical tape) for repair of cuts in remote control conduits.
- Safety glasses.

### Remote Control Maintenance Requirements

- 1 Disconnect the remote control unit from the exposure device.
- 2 Straighten out the remote control housings on a work surface, then remove the control cable from the remote control conduits (661 safety connector side) until it stops (a stop spring on the end of the control cable). Rubber gloves are recommended for this operation. Do not use excessive force during removal of the control cable. During removal of the control cable, it should be coiled in loops no less than a 12 in (305 mm) diameter and secure.
- 3 Disconnect the remote control conduit fitting from the control crank using the 11/16 in open-end wrench. Remove the stop spring from the end of the control cable and pass the control cable through the crank gear to completely disengage. Label the remote control conduits for proper assembly after the servicing.
- 4 Pull the remaining control cable through the 661 safety connector and secure.
- 5 Using the 11/16 in open-end wrench, remove both remote control conduits from the 661 safety connector and the control crank.
- 6 Thoroughly clean the control cable using a brush in a degreaser bath. Use compressed air to blow off residual solvent after the degreasing operation. Be sure to follow the solvent manufacturer's safety recommendations.



- 7 Perform the following inspections of the control cable:
- a. Use the Model 550 NO GO gauge to inspect the control cable connector for wear. Closely inspect the connector for bends or cracks in the neck (shank) area and dented areas on the ball of the connector. Remove the control cable from service if any cracks or bends in the shank or dents in the ball of the male connector are found during this inspection. The male connector should not be bent at an angle greater than 15 degrees from the axis of the control cable in the area where it is crimped. Using your hands, attempt to twist or rotate the male connector off the control cable. If any movement is possible during this test, the control cable must be removed from service and the male connector must be replaced.
  - b. Carefully inspect the control cable directly behind the remote control cable connector and approximately 12 in (305 mm) beyond the male connector looking for the following anomalies:
    - Cuts, breaks, nicks or fraying in the spiral windings of the cable.
    - Kinks or permanent bends.
    - Rust (red oxide) on the inner and outer core of the cable.
    - Uniformity of the spacing between the outer helical windings of the cable. Check for flattened areas and excessive wear that reduces the cable's outer diameter less than 0.183 in (4.7 mm).
    - Perform a flexibility (spring) test of the cable by bending the connector end of the cable into a 'U' shape and then releasing it. A cable that is bent/released and does not spring back into an essentially straight shape is indicative of internal corrosion of the cable. The cable must be removed from service.
    - Carefully examine the cable in the area of the control crank assembly looking for cuts, breaks, fraying, rust, unusual stiffness and uniformity of the spacing between the outer spiral windings.
    - Examine the entire length of cable looking for defects described above.

If a control cable is deemed as defective during this inspection, remove it from service and tag it with a label to prevent inadvertent use.

The control cable (Model 550 male) connector must be replaced at intervals **not to exceed five (5) years**. Maintenance program administrators must maintain traceability records for replacement of all 'Safety Class A' designated components.

- 8 Lightly lubricate the control cable using MIL-G-23827B (or C), MIL-PRF-23827C, or equivalent grease. Apply additional grease to the first 3 ft (approximately 1m) of control cable (male connector end).
- 9 Clean the exterior of the remote control conduits using clean rags and a detergent. Remove all dirt and grease from the polyvinyl conduits and swaged fittings. Carefully inspect the entire length of remote control conduits for cuts and melted areas. Repairs to cut or melted areas can be accomplished by taping the area with 3M™ yellow polyvinyl tape (or black polyvinyl electrical tape). The tape will prevent the ingress of water and other liquid that would cause corrosion of the remote control conduit's inner braids and the remote control cable. Look and feel for dents and depressions in the remote control conduits. Minor dents can be rounded out by gently tapping the area with a small hammer.

Examine the control conduits where they protrude from the swage fittings, looking for bulges or cracks in the polyvinyl. Remote control conduits with large dented areas or cracks/ bulges near the swage fittings should be sent to the manufacturer for repairs.

Clean the interior of both remote control conduits by pouring 4-5 oz (100 ml) of clean solvent into one end. Use compressed air to blow the solvent through the entire length of conduits into a clean white cloth attached to the opposite end. Repeat this cleaning process until the solvent blown through the conduit comes out clean. Use the compressed air to thoroughly dry the interior of the conduit. Residual solvent left in the remote control conduit will dilute the lubrication applied to the remote control cable diminishing the protective qualities.

Check the swage fittings to ensure the threads are not stripped and are clean. Using your hands, attempt to twist or rotate the swage fittings off the control conduits. If any movement is possible, the control conduit must be removed from service and new swage fittings must be installed.

- 10 Remove the crank arm from the control crank assembly by removing the 5/16 in hex bolt and washer.

While wearing safety glasses, carefully remove the control crank assembly from the handle or frame by unscrewing the four bind head screws from the stop nuts.

Separate the two halves of the control crank housing.



### CAUTION

Ensure the cable adapters stay in the bottom control crank housing during separation. Care should be taken to avoid losing control of the tensioned wear strip that may fly out during separation of the control crank housing. **This is the reason why safety glasses must be worn.**

Disassemble and degrease the drive wheel, wear strip, the two cable adapters, the two brake jaws, the two halves of the control crank housing and brake bearing. The wheel bearings may be left in the control crank housing during cleaning, but care should be taken not to lose the spacer rings that fit between the wheel bearings and the drive wheel as applicable. Clean and inspect all parts for damage or wear and replace as necessary.

If applicable, remove the reset knob of the odometer by loosening the two Allen set screws, then remove the odometer cover by removing the two bind head screws that fasten it to the mounting plate. Do not disassemble the odometer.

Clean the helical gear of the odometer with solvent using a brush to dislodge any material between the gear teeth. Check the odometer for proper operation: turning the gear should turn the odometer but the odometer shaft should still be able to turn when the gear is held fixed (for zeroing the odometer).

Clean the drive wheel in solvent using a brush to dislodge any dirt between gear teeth. Inspect the drive wheel's gear teeth looking for broken or bent teeth. If the drive wheel has broken or bent teeth, use a file to grind the tooth flush with the drive wheel. Up to three consecutive teeth can be missing from the drive wheel before a replacement is required.

Light rust may be removed from the wear strip using fine sandpaper and machine oil.

Lightly grease the drive wheel hub, wheel bearings and the wear strip before reassembling.

Place one of the cable adapters in the lower control crank housing. Place one end of the wear strip against the cable adapter then fit the rest in the track of the housing. Fit the other cable adapter in place to retain the wear strip.





### CAUTION

**Wear safety glasses** when inserting the wear strip. It will be under tension and could suddenly fly out during assembly.

Place the drive wheel in the lower half of the control crank housing making sure the spacer rings are between it and the wheel bearings if applicable.

Assemble the two brake jaws, brake bearing and brake arm. The angled sides of the brake jaws should be facing the retract side of the control crank housing.

Place the upper control crank housing over the assembly while keeping them level and press them together.

Check that the control crank mechanism is properly assembled by turning the shaft. It should spin freely.

Check the operation of the friction brake while holding both halves of the control crank housing together tightly. If it does not function correctly, check for faulty assembly or excessively worn brake jaws.

As applicable, mount the control crank housing on the frame or handle with the four bind head screws and stop nuts. Secure the crank arm to the shaft using the 5/16 in washer and hex bolt.

For reel type controls, secure the odometer cover to the mounting plate with two bind head screws. Secure the odometer's reset knob to the shaft by tightening the two Allen head screws, leaving clearance between the knob and the cover.

After assembly, perform a check to ensure the control crank will turn freely. Set the brake lever to the ON position and attempt to turn the handle using moderate pressure. Do not apply excessive force. Run a section of the control cable through the control crank to ensure the control crank operates easily without snags or resistance.

If applicable, make sure the odometer turns when the crank handle is turned. If the odometer does not function during this test, check for improper assembly or damaged parts.

- 11 Clean the 661 safety connector assembly using a brush and solvent. Ensure the movable jaws of the safety connector are not excessively loose or worn where they swivel in the clevis pins. Examine the connector collar for bent or loose connecting pins and excessive wear on the inner-mating surface. Examine the face of the connector body where the control cable protrudes and verify that long-term usage has not chamfered the area.

### Re-assembly of the Remote Control Unit:

Reattach the remote control conduits to the safety connector assembly. Attach the EXPOSE sheath to the EXPOSE side of the control crank assembly.

Lay the remote control conduits out in a straight line or a wide loop. Feed the end of the control cable into the conduit as far as it will go. As the control cable is being fed into the remote control conduits, feel for any resistance that indicates damage of the remote control conduit.

Turn the control crank handle in the RETRACT direction until the end of the control cable is protruding. Screw the safety stop spring onto the end of the control cable approximately 2 in (50 mm) from the end.



Connect the RETRACT control housing to the control crank housing. Retract the control cable fully, watching for any binding that may indicate damage to the control housing.

If applicable, reset the odometer to zero with the control cable fully retracted.

Replace the protective rubber cap over the end of the safety connector assembly.

### Quarterly and Annual Maintenance for the Extreme Condition Remote Controls

#### Tools required for complete maintenance of Models 882 and 885 extreme remote controls:

- 11/16 inch open-end wrench for the control conduit swage fittings.
- 1/2 inch open-end wrench for the 5/16 inch control crank handle bolt.
- 1/8 inch Allen wrench for the 8-32 hex-head remote control crank screws (SCR-252).
- 1/8 inch drill, #21 drill bit.
- Control cable run-off prevention (stop) spring removal tool if required.
- Model 550 connector NO GO gauge for wear check of the control cable connector.
- X4 to X7 magnification glass for control cable inspection if required.
- Micrometer for measurement of control cable diameter.

#### Materials required for complete maintenance of Models 882 and 885 remote controls:

- Clean solvent: fresh mineral spirits recommended for cleaning and degreasing remote control mechanism, control cable and cleaning the control conduits internally. (Follow manufacturer's safety precautions for use, handling, storage and disposal.)
- Large pan for cleaning and degreasing the control crank assembly and control cable.
- Clean lint-free rags and detergent to clean the exterior of the control conduits.
- Mil-spec grease, MIL-G-23827B (or C), MIL-PRF-23827C (or equivalent radiation resistant grease) for lubricating the control cable and control crank mechanism.
- Stainless steel, brass or synthetic bristle brush to clean control crank parts and the control cable.
- Compressed air source and hand nozzle to blow dry the control cable internal Teflon™ liner of the remote control conduits after cleaning.
- 3M™ yellow polyvinyl tape (or black polyvinyl electrical tape) for repair of cuts in remote control conduits.
- Loctite™ 242 temporary thread sealant or equivalent.

#### Remote Control Maintenance Requirements

- 1 The remote control unit must be disconnected from the exposure device for inspection and maintenance. A "misconnect test" can be performed before servicing to verify if unsafe wear is present.
- 2 Straighten out the remote control housings on a work surface, then check for freedom of movement of the control cable within the remote controls by moving the control crank handle back and forth approximately one-quarter turn. During this test, take care to avoid cranking the control cable onto the ground exposing it to dirt and sand. If any resistance is felt during this check, inspect the control conduits for dents or depressions. If dents or depressions are not present on the remote control conduits, the control cable may be rusted stiff somewhere within the control conduits or the control crank internal housing may contain dirt or debris. After the operational check, remove the control cable from the remote control conduits (661 safety connector side) until it stops (a stop spring on the end of the control cable). Rubber gloves are recommended for this operation. Do not use excessive force during removal of the control cable. During removal of the control cable, it should be coiled in loops no less than a 12 in (305 mm) diameter.
- 3 Disconnect the remote control conduit fitting from the control crank using the 11/16 in open-end wrench. Remove the stop spring from the end of the control cable and pass the control cable through the crank gear to completely disengage. Label the remote control conduits (hand crank end / safety plug assembly end) for proper assembly after the servicing.
- 4 Pull the remaining control cable through the 661 safety connector and secure using tie wraps or equivalent.

- 5 Using the 11/16 in open-end wrench, remove both remote control conduits from the 661 safety connector and the control crank.
- 6 Thoroughly clean the control cable using a brush in a degreaser bath. Use compressed air to blow off residual solvent after the degreasing and cleaning operation.



### CAUTION!

Be sure to follow the solvent manufacturer's safety instructions and Material Safety Data Sheet recommendations.

- 7 Perform the following inspections of the control cable:
  - a. Use the Model 550 NO GO gauge to inspect the control cable connector for wear. Closely inspect the connector for bends or cracks in the neck (shank) area and dented areas on the ball of the connector. Remove the control cable from service if any cracks or bends in the shank or dents in the ball of the male connector are found during this inspection. The male connector should not be bent at an angle greater than 15 degrees from the axis of the control cable in the area where it is crimped. Using your hands, attempt to twist or rotate the male connector off the control cable. If any movement is possible during this test, the control cable must be removed from service and the male connector must be replaced.
  - b. Carefully inspect the control cable directly behind the remote control cable connector and approximately 12 in (305 mm) beyond the male connector looking for the following anomalies:
    - Cuts, breaks, nicks or fraying in the spiral windings of the cable.
    - Kinks or permanent bends.
    - Rust (red oxide) on the inner and outer core of the cable.
    - Uniformity of the spacing between the outer helical windings of the cable. Check for flattened areas and excessive wear that reduces the cable's outer diameter less than 0.183 in (4.7 mm).
    - Perform a flexibility (spring) test of the cable by bending the connector end of the cable into a 'U' shape and then releasing it. A cable that is bent / released and does not spring back into an essentially straight shape is indicative of internal corrosion of the cable. A 'crunching' feeling and stiffness when bending the cable into the "U" shape is another confirmation of the problem. The drive cable must be removed from service.
    - Carefully examine the drive cable in the area of the control crank assembly looking for cuts, breaks of the inner and outer spiral metal windings, fraying, rust, unusual stiffness and uniformity of the spacing between the outer spiral windings.
    - Examine the entire length of cable looking for defects described above.

If a control cable is deemed as defective during this inspection, remove it from service and tag it with a label to prevent inadvertent use.

The control cable (Model 550 male) connector must be replaced at intervals **not to exceed five (5) years**. Maintenance program administrators must maintain traceability records (lot numbers) for replacement of all "Safety Class A" designated components.

- 8 Lightly lubricate the control cable using MIL-G-23827B (or C), MIL-PRF-23827C, or equivalent grease. Apply additional grease to the first 3 ft (approximately 1m) of control cable (male connector end).
- 9 Clean the exterior of the remote control conduits using clean rags and a detergent. Remove all dirt and grease from the polyvinyl conduits and swaged fittings. Carefully inspect the entire length of remote control conduits for cuts and melted areas. Repairs to cut or melted areas can be



accomplished by taping the area with 3M™ yellow polyvinyl tape (or black polyvinyl electrical tape). The tape will prevent the ingress of water and other liquid that would cause corrosion of the remote control drive cable. Visually inspect and feel for dents and inward depressions on the remote control conduits. The extreme control conduits are dent resistant, but may have flattened areas or cuts due to impacts.

Remove the spring duplex strain relief assembly and examine the control conduits where they protrude from the swage fittings, looking for bulges or cracks in the polyvinyl. Remote control conduits with large dented areas or cracks/ bulges near the swage fittings must be sent to the manufacturer or authorized service center for repairs.

Clean the interior of both remote control conduits by pouring 4-5 oz (100 ml) of clean solvent into one end. Use compressed air to blow the solvent through the entire length of conduits into a clean white cloth attached to the opposite end. Repeat this cleaning process until the solvent blown through the conduit comes out clean. Use the compressed air to thoroughly dry the interior of the conduit. Residual solvent left in the remote control conduit will dilute the lubrication applied to the remote control cable diminishing the protective qualities.

Check the swage fittings to ensure the threads and hex nuts are not stripped and are clean. Using your hands, attempt to twist or rotate the swage fittings off the control conduits. If any movement is possible, the control conduit must be removed from service and new swage fittings must be installed.

- 10 Remove the crank arm assembly with brake from the control crank assembly by removing the 5/16 inch hex bolt and washer. Check the hand crank knob (tee-handle) pin (part number 95010) for looseness or excessive wear. Replace worn knob pin by removing roll-pin (part number PIN024), replace knob pin (part number 95010) and then insert a new roll pin (part number PIN024). Check brake assembly for proper on and off operation and verify the spring tension is adequate to maintain the set position. Compare the crank arm assembly to a new crank arm assembly for conformity to shape. If required, a bent crank arm can be mounted into a vise and bent back into its original shape.

Disassemble the control crank assembly by unscrewing the six socket-head screws (part number SCR252) using a 1/8 inch Allen wrench.

Separate the drive gear cover (steel plate, part number 95002-6) from the molded grip handle body of the control crank. Inspect the drive gear cover plate label (part number 95007-01 or 95006-01) to ensure the “expose” and “retract” and arrows indicating the direction of travel is legible. Replace the operator instruction label if damaged or illegible.

Inspect the molded grip handle body (part number 95003-6) to ensure the tubular spacers (part number 95003-6) are all present. The tubular spacers prevent over-compression and distortion of the black molded grip handle when the six socket-head screws are tightened. Inspect the black plastic handle body for cracks near the conduit fittings and the ball bearing housing. Inspect the black plastic handle body for its general condition to ensure it's not deformed as the result from exposure to high temperature and there are no cracks or perforations in the plastic housing that could allow the ingress of foreign materials such as water, sand, mud or fly ash.

Disassemble, clean and degrease the drive gear (part number 95005), interior surface of the molded grip handle and drive gear cover (part number 95002-6), the two conduit fittings and the external surfaces of the ball bearings (part number BBS032). Inspect the ball bearings to ensure the rubber seals are not cracked or worn through. Check the ball bearings for smooth and free movement by holding the inner hub stationary and rotating the outer hub. These are sealed ball bearings and do not require additional lubrication.

Inspect the two rubber seals, 15mm seal (part number RIN024) and the large O-ring seal (part number RIN026) for cracks, cuts or abrasion that would warrant replacement. If the rubber seals are deemed satisfactory after this inspection, apply a light coating of grease to these seals.



Clean the drive gear in solvent using a brush to dislodge any dirt between drive gear's teeth. Inspect the drive wheel's gear teeth looking for broken or bent teeth. If the drive wheel has broken or bent teeth, use a file to grind the tooth flush with the drive wheel. Up to three consecutive teeth can be missing from the drive wheel before a replacement is required.

Light rust may be removed from the wear strip using fine sandpaper and machine oil.

Lightly grease the wear strip before reassembling.

### **Reassembly of the remote control handle assembly:**

Install the ball bearing (part number BBS032) into the steel insert of the molded grip handle. Insert the drive gear in the ball bearing already placed in the crank housing. Rotate the drive gear (part number 95005) to ensure free movement and proper seating. Install the second ball bearing (BBS032) onto drive gear shaft and rotate to ensure proper seating of the installed components. Install the lubricated large diameter O-ring seal onto the back side of the drive gear cover plate and seat into the molded grip handle body. The serial number of the drive gear cover plate should be positioned five o'clock position relative to the hand grip at the six o'clock position. Install the lubricated 15 mm rubber seal onto the drive gear shaft while making sure it's seated within the drive gear cover plate.

Apply Loctite 242 onto the first four threads of socket head screws (part number SCR252). Ensure the tubular spacers (part number 95003-6) are all present. The tubular spacers prevent over-compression and distortion of the black molded grip handle when the six socket-head screws are tightened. Install and hand tighten the six socket head screws (part number SCR252) and flat washers (part number WSH047) into the back of the molded grip handle body using the 1/8 inch Allen wrench. Install the crank arm assembly onto the drive gear shaft at the 9:00 o'clock position relative to the 6:00 o'clock position of the hand grip. Apply temporary Loctite 242 to the first four threads of the 5/16 inch bolt. Install the 5/16 inch hex-head bolt (part number SCR219-03) and washer (WSH045) and hand tighten using a 1/2 inch open-end wrench.

After assembly, verify the control crank mechanism is properly assembled by turning the crank arm. It should spin freely. Check the operation of the brake's plunger knob.

For reel type controls, apply Loctite 242 to the first four threads of the flat socket head screws. Mount the control crank housing on the reel type frame with the two flat socket head screws (part number SCR350) and 2 thrust plates (part number 95063).

After assembly, perform a check to ensure the control crank will turn freely. Set the brake plunger knob to the ON position (engaged on the drive gear cover plate) and attempt to turn the handle using moderate pressure. Do not apply excessive force. Run a section of the control cable through the control crank to ensure the control crank operates easily without snags or resistance.

- 11** Clean the 661 safety connector assembly using a brush and solvent. Ensure the movable jaws of the safety connector are not excessively loose or worn where they swivel on the Spirol pins (part number PIN016). Attempt to push the pins out using the back end of a 1/8 inch drill bit or a drift punch. If they can be moved by pushing, replace the pins. Visually look for cracked Spirol pins from both sides of the safety connector. Replace the Spirol pins if there is any evidence of cracked or broken pins. Examine the connector collar for bent or loose connecting pins and excessive wear on the inner-mating surface. Examine the face of the connector body where the control cable protrudes and verify that long-term usage has not chamfered the area.



### Re-assembly of the Remote Control Unit:

If required, install the spring duplex strain relief assembly on the opposite end of the remote control conduits from which it was removed. This will promote even wear of the remote control conduits. Reposition the spring strain relief assembly by sliding it down the entire length of conduits to the opposite end. Apply heavy-duty shrink wrap or wrap PVC tape, near the end the spring to prevent chafing of the conduits. Reattach the remote control conduits to the safety connector assembly. Attach the EXPOSE sheath (yellow side of the joined conduits) to the EXPOSE side of the control crank assembly.



#### **CAUTION! Do not over-tighten these fittings.**

Lay the remote control conduits out in a straight line or a wide loop. Feed the end of the control drive cable into the conduit as far as it will go. As the control cable is being fed into the remote control conduits, feel for any resistance that indicates damage of the remote control conduit.

Turn the control crank handle in the RETRACT direction until the end of the control cable is protruding. Screw the safety stop spring onto the end of the control cable approximately 2 in (50 mm) from the end.

Connect the RETRACT control housing (black side of the joined conduits) to the control crank housing. Fully retract the remote control drive cable while feeling for any binding that may indicate damage to the control housings. Perform a freedom of movement test as described part two of this section.



#### **CAUTION! Do not over-tighten these fittings.**

Perform a “misconnect test” of the serviced remote controls on a QSA Global Inc. exposure device locking mechanism to confirm the remote control assembly is free from long term wear or damage the could cause the a failure of the interrelated failsafe system that includes the control drive cable connector, safety plug assembly, device locking mechanism and sealed source connector.

Replace the protective rubber cap over the end of the safety connector assembly.

Record all inspections conducted, all maintenance performed and components that were replaced on the remote controls. Identify the remote controls with the serial number that is etched on the stainless steel drive gear cover. See “Annual Maintenance Records” section.

Extreme controls descriptive: The lightweight, extreme controls were designed for operation in -40° C to 100° C temperatures while providing users with a rugged, water-resistant, crush-resistant weld-joined control housings matched to an ergonomically designed hand crank. The extreme remote controls are compatible with all QSA Global, Inc. crank-out radiographic exposure devices.

### Quarterly and Annual Maintenance for Source Guide Tubes

#### Tools required for maintenance of source guide tubes:

- A424-9XL mock source assembly to perform function tests after cleaning and inspection.
- Length of clean control cable to push A424-9 XL through a 7 ft (2.1 m) source guide tube.
- 1 in-18 tap and 1 in-18 die for male and female threads of the source guide tubes, if required.

#### Materials required for maintenance of source guide tubes:

- Solvent: Clean mineral spirits to clean the source guide tubes internally.
- Clean lint-free cloths and detergent to clean the exterior of the source guide tubes.
- Mil-spec grease MIL-G-23827B (or C), MIL-PRF-23827C (or equivalent radiation resistant grease) to lubricate the swage fittings on the source guide tubes.
- Source of compressed air and hand nozzle to blow dry the internal conduit of the source guide tubes.
- 3M™ yellow polyvinyl tape (or black polyvinyl electrical tape) for repair of cuts in the source guide tubes.
- Loctite™ 242 temporary thread sealant or equivalent for bayonet adaptor threads.

### Source Guide Tube Maintenance

- 1 Clean the exterior of all the source guide tubes thoroughly using clean cloths and a detergent. Remove all of dirt, grease and grime from the yellow polyvinyl source guide tubes and the swage fittings.
- 2 Clean the interior of each source guide tube by pouring 4-5 oz (100 ml) of clean solvent into one end. Manipulate the source guide tube back and forth to cause the solvent to wash the interior of the entire length of source guide tube. Pour the solvent into a used solvent container. Refill the source guide tube with clean solvent and repeat the cleaning operation. Repeat this cleaning process until the solvent poured out of the source guide tube into the used solvent container is clean. Use a compressed-air hose to blow out any residual solvent from the source guide tubes. Use of a clean white cloth attached to one end of the source guide tube will trap any debris or residual solvent when blowing out the source guide tubes. Repeat the cleaning process until the cloth 'trap' indicates dirt is not present within the source guide tubes.
- 3 Carefully inspect the entire length of each source guide tube for cuts and melted areas. Repairs to cut or melted areas can be accomplished by taping the area with 3M™ yellow polyvinyl tape (or black polyvinyl electrical tape). Taping the damaged area of the polyvinyl sheath will prevent the ingress of water and other liquid that would cause corrosion to the remote control cable. Carefully look and feel for dents and depressions in the source guide tubes. Even a small inward dent in the source guide tube could cause a seized source assembly resulting in emergency operations. A 'mock' (Model A424-9XL) source assembly attached to a section of control cable that is pushed through the entire length of source guide tube provides additional confirmation the source guide tube suitable for use. Inspect the swage fittings of each source guide tube to ensure the threads are not stripped or galled. If the threads are damaged, the use of a 1 in-18 tap or die and oil can be used to clean the damaged area. Using moderate pressure, attempt to twist the swage fitting off the source guide tube. If any movement is possible, remove from service and replace the swage fitting. Inspect the source guide tube near the swage fitting for breaks and bulging, remove from service and send to a service center for repairs. Inspect the exposure head (source stop) for excessive wear or perforations on the end-stop and the side where the collimator (beam limiter) is mounted. Damaged fittings or exposure heads on source guide tubes can be replaced at a QSA Global service center. If the swage fittings are not damaged and are securely attached to the source guide tube, apply a light coat of grease to the threads and install the protective covers over the fittings.

Inspect the ears (flanges) on the bayonet adaptors to ensure they are not bent, broken or excessively worn. Inspect the three piece design bayonet (88081, no longer manufactured) to verify the separation gap is not excessively wide or loose. (This indicates the screw-on portion may have loosened and should be serviced). To service, disassemble using a large slot screwdriver, clean in solvent, apply Loctite™ 242 temporary thread sealant or equivalent on bayonet adaptor threads. Reassemble using slot screwdriver (hand tighten only) and let dry for 24 hours. Inspect the swaged two piece design bayonet (88082) (This bayonet is engraved with “880”.) for damage or excessive wear on the ears (flanges). For either bayonet, verify the bayonet adaptor rotates freely between the female fitting and the fixed bayonet section. After cleaning and visual inspections, engage the bayonet in the outlet port of an exposure device to ensure smooth operation and to ensure the bayonet is not too loose when fully engaged. Remove any bayonet from service that is not satisfactory in the visual or operational inspections. Be sure to install a status indicator on the bayonet if removed from service.

### **Misconnect Test After Reloading Sealed Source into the Exposure Device:**

#### **Misconnect Test**

After performing the annual maintenance, the complete radiography system must be tested by the maintenance program administrator or Radiation Safety Officer. A misconnect test on the exposure device including the radioactive source assembly and remote controls effectively tests the integrity of the entire locking system. This procedure detects long-term wear (or damage) of the interrelated failsafe system including identification of any excess wear on the safety connector assembly, the drive cable connector, the exposure device automatic securing mechanism and the source assembly connectors simultaneously.

**Note: Component wear occurs to both the control assemblies and the device locking mechanisms over time, therefore, to ensure acceptable equipment operation, the misconnect test must be performed on each device lock assembly and control assembly that will be used for radiographic operations. All remote controls must be tested using a QSA Global, Inc. manufactured automatic securing mechanism equipped with a QSA Global, Inc. manufactured source assembly, 550 jumper or A424-9XL mock source assembly to ensure the effectiveness of the misconnect test.**

The test should only be performed by personnel that are formally trained, authorized and thoroughly familiar with annual maintenance procedures. This test is performed by engaging the remote control connecting plug assembly into the exposure device's locking mechanism **WITHOUT** first engaging the control cable connector within the source assembly connector.

The ability to then rotate the locking mechanism from the CONNECT position towards the LOCK position indicates critical dimensions of the locking system are excessively worn to an unsafe condition. **Extreme care should be exercised to prevent rotating the locking mechanism's selector ring beyond the LOCK position.** If the locking mechanism and remote controls fail a misconnect test the equipment must be removed from radiographic operations. The equipment must not be used until repairs are performed and misconnect test results are satisfactory.

During the performance of the misconnect test there is a **risk of losing control of the radioactive source assembly if:**

- the components are excessively worn or damaged
- the person performing the test intentionally or inadvertently rotates the selector ring from the CONNECT position to the OPERATE position
- the person performing the test intentionally or inadvertently pushes the lock slide into the EXPOSURE mode.

Contact a QSA Global, Inc. service center if you have questions regarding the misconnect test.

### Annual Maintenance Records

Records of all equipment inspected and maintained during the annual maintenance must be recorded. Records should indicate:

- The date of the inspection and maintenance.
- The name of the qualified individual performing the required inspections.
- Record problems found and maintenance or repairs performed. Include results of misconnect tests on all remote controls and exposure devices by manufacturer, model number and serial number.
- The model number and serial number of the exposure device.
- The associated equipment including the model number of remote controls (serial number if serialized) and source guide tubes that were inspected and maintained.
- The part numbers and associated lot numbers or serial numbers of replacement parts installed.

### Model 880 Series Safety Class A Components

#### Safety Class A Designation Items

Items that comprise the Model 880 Series radiographic exposure device and associated equipment that are critical for safe radiological operation are classified as Class A items or components. Class A items can be structures, components and systems whose failure or function could directly result in a condition adversely affecting public health and safety. This would include extreme conditions such as the loss of primary containment with a subsequent release of radioactive material and or a loss of shielding creating a substantial safety hazard. Replacement parts that are sent to you with a safety Class A designation are clearly marked with lot numbers and contain instructions to maintain traceability.

#### Considerations of Safety Class A Items

Users of the Model 880 Series exposure devices and associated equipment must recognize their responsibilities of maintaining the integrity of the Type B(U)-96 (or Type A) package and the control of Safety Class A items and components by:

- maintaining traceability of Class A replacement items or components to a specific exposure device or an associated component.
- use of manufacturer specified items to maintain the integrity of the exposure device/transport package according to the certifications. Do not use generic grade items or components that do not meet original design specifications.
- performance of periodic inspections to verify the Class A items are not excessively worn from long term use or have been damaged from accidents.
- use and handling of the system consistent with its design and intended application.
- promptly notifying the manufacturer in the event a Safety Class A item or component which contains a defect or deviates from the original design specifications. This action will initiate a formal evaluation of the defect or deviation.



### REAR PLATE ASSEMBLY

ITEM	PART NO.	QTY.	DESCRIPTION
1	88014	1	LOCK COVER ASSEMBLY
2	85701-5	1	SELECTOR RING RETAINER
3	88026	1	SELECTOR RING
4	SPR005	1	COMPRESSION SPRING
5	88025	1	SLEEVE
6	88024	1	LOCK SLIDE
7	SPR006	1	COMPRESSION SPRING
8	66001-6	2	ANTI-ROTATE LUGS
9	SPR004	2	COMPRESSION SPRING
10	88021	1	REAR PLATE

ITEM	PART NO.	QTY.	DESCRIPTION
11	SCR002	4	SOCKET HEAD CAP SCREW
12	SCR072	2	SOCKET HEAD CAP SCREW
13	SLV005	4	RUBBER SLEEVE
14	88022	1	LOCK MOUNT
15	66001-11	1	LOCK ASSEMBLY
16		2	LOCK PIN (Supplied with 66001-11)
17		2	LOCK SPRING (Supplied with 66001-11)
18	SCR023	1	SOCKET HEAD CAP SCREW
19	66001-811	2	KEY
20	66001-20	1	DUMMY CONNECTOR

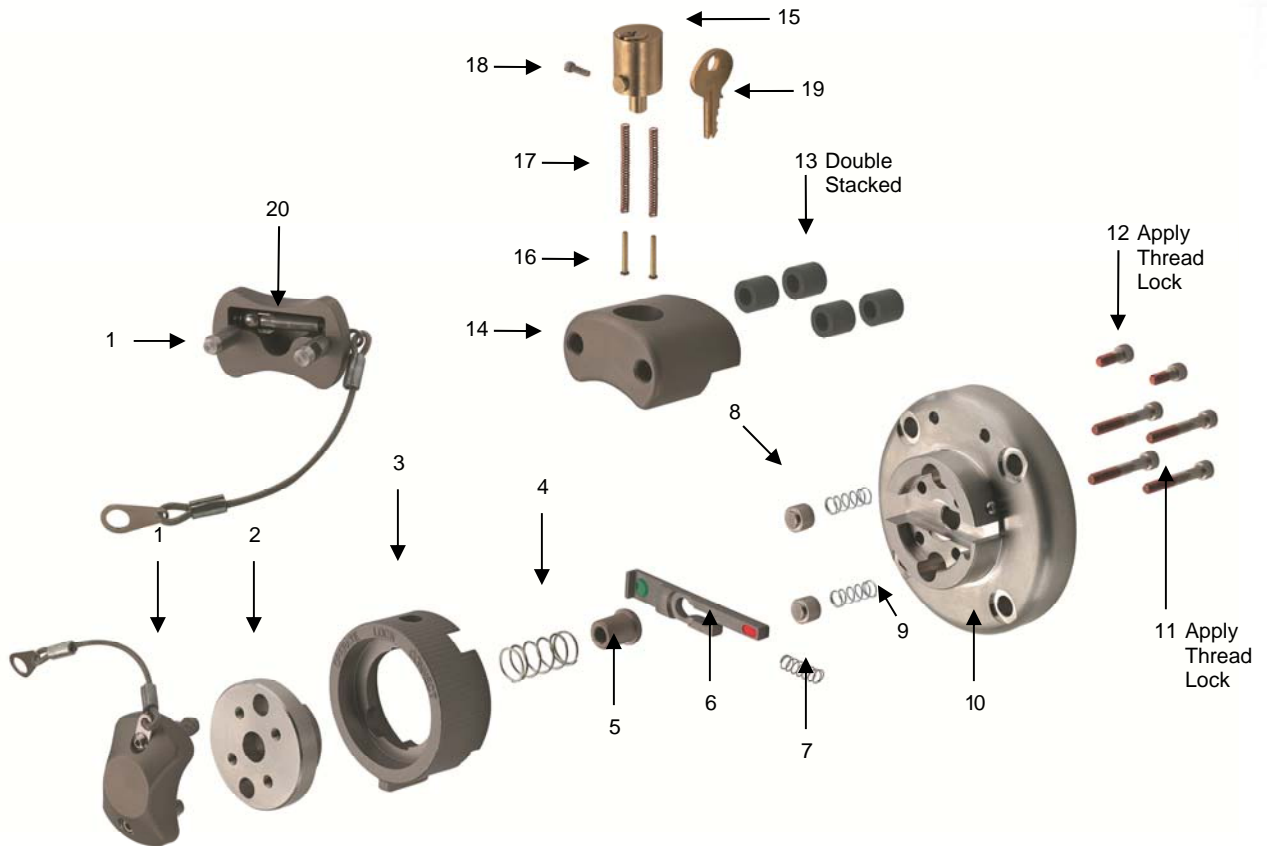

### Assembly process for lock assembly, sleeve and lock mount:

1. Insert the stainless steel sleeve, 88022-1 into the large hole in the lock mount, 88022.
2. Align the small hole in sleeve with the 8-32 threaded hole in lock mount.
3. Apply a drop of thread lock, GLU002, to the middle threads of set-screw, SCR225 and let it dry (about 1 minute).
4. Carefully install set-screw, SCR225, into the 8-32 threaded hole in the lock mount until the Sleeve is secure. The dog point of the set-screw should engage in the hole in the sleeve. **DO NOT OVERTIGHTEN the set-screw** or the sleeve will be damaged.
5. Install the brass plunger lock and check its actuation.

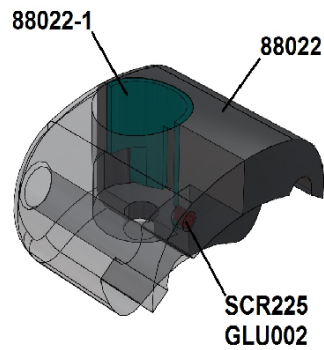

PARTIAL SECTION VIEW

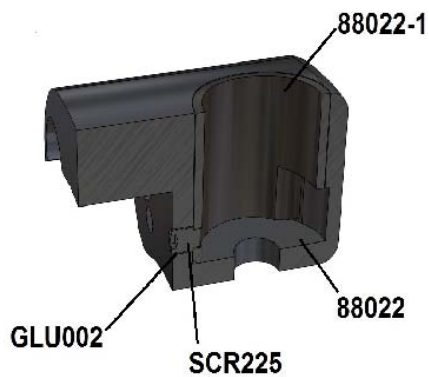

X-SECTIONAL VIEW

**Front Plate Assembly**





### FRONT PLATE ASSEMBLY

ITEM	PART NO.	QTY.	DESCRIPTION
1	88033	1	PORT COVER (SET SCREW TYPE)
•	88033A	1	PORT COVER (ROLL PIN TYPE)
2	SCR162	1	SET SCREW
•	SCR251	1	SET SCREW
•	PIN036	1	ROLL PIN
3	88031	1	FRONT PLATE
4	88036	2	WASHER
5	88032	1	ROTOR (ROLL PIN TYPE)
•	88032A	1	ROTOR (SET SCREW TYPE)
6	SPR033	2	COMPRESSION SPRING
7	88037	1	SHAFT (SET SCREW TYPE)
•	88037A	1	SHAFT (ROLL PIN TYPE)

ITEM	PART NO.	QTY.	DESCRIPTION
8	PIN024	1	ROLL PIN
•	PIN058	1	ROLL PIN
9	SCR160	2	SOCKET HEAD CAP SCREW
10	88039	1	PIVOT DISK
11	88034	1	PORT SHIELD (ROLL PINTYPE)
•	88034A	1	PORT SHIELD (SET SCREW TYPE)
12	PIN038	1	ROLL PIN
•	SCR157	1	SET SCREW
13	88035	1	SLIDER

- COMPONENTS ON SOME MODELS DIFFER SLIGHTLY FROM THOSE ILLUSTRATED-CHECK PART NUMBER BEFORE ORDERING

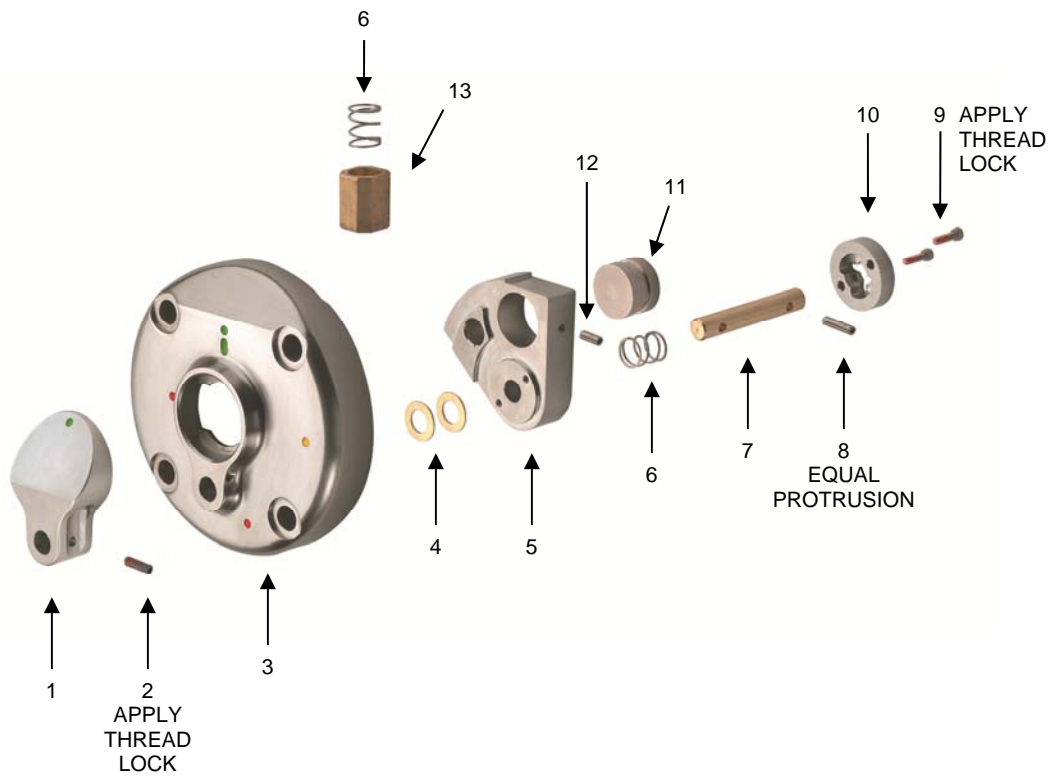

### CONTROL ASSEMBLIES

Model Numbers: 692, 693 and 664 series



### SOURCE GUIDE TUBES

Model Numbers: 48906, 48907, 489930, 48931, 95020 and 95021 series



### REMOTE CONTROL HAND CRANK ASSEMBLIES Model numbers: 692, 693 and 664

ITEM	PART NO.	QTY.	DESCRIPTION
1	SCR125	4	1/8 IN BIND HEAD SCREW ●
2	SCR008	4	1/4 IN BIND HEAD SCREW ○
3	BLT008	1	HEXAGONAL BOLT
4	WSH019	1	WASHER
5	68901	1	CRANK ARM
6	BBS-004	1	BRAKE BUSH
7	81800-10	2	CONTROL CRANK HOUSING
8	68900-8	1	CRANK DECAL
9	68900-4	2	BRAKE JAW
10	68900-3	1	BRAKE ARM
11	BBS-001	2	BALL BEARING ASSEMBLY
12	68900-7	1	WEAR STRIP
13	81800-1	1	DRIVE WHEEL
14	68900-2	2	CABLE ADAPTER
15	69302-1	1	GEAR SHAFT ●
16	BBS-007	1	OILITE BEARING ●
17	PIC-003	1	WASHER ●

ITEM	PART NO.	QTY.	DESCRIPTION
18	GEA-002	1	HELICAL GEAR
19	PIN008	1	ROLL PIN
20	66404-1	1	GEAR SHAFT ○
21	BBS-005	1	OILITE BEARING ○
22	NUT025	4	STOP NUT
23	66103	1	SAFETY CONNECTOR
	66101-4	1	CABLE PLUG
24	59125	2	25 FT (7.6 M) HOUSING
	59135	2	35 FT (10.7 M) HOUSING
	59150	2	50 FT (15.2 M) HOUSING
25	55005	1	50 FT (15.2 M) CONTROL CABLE
	55010	1	70 FT (21.3 M) CONTROL CABLE
	55009	1	100 FT (30.5 M) CONTROL CABLE
26	69303-	1	ODOMETER ASSEMBLY ●
27	69201-3	1	HANDLE ●
28	66410	1	FRAME ○
29	66403-	1	ODOMETER ASSEMBLY ○

● PISTOL GRIP MODEL ○ REEL TYPE MODEL

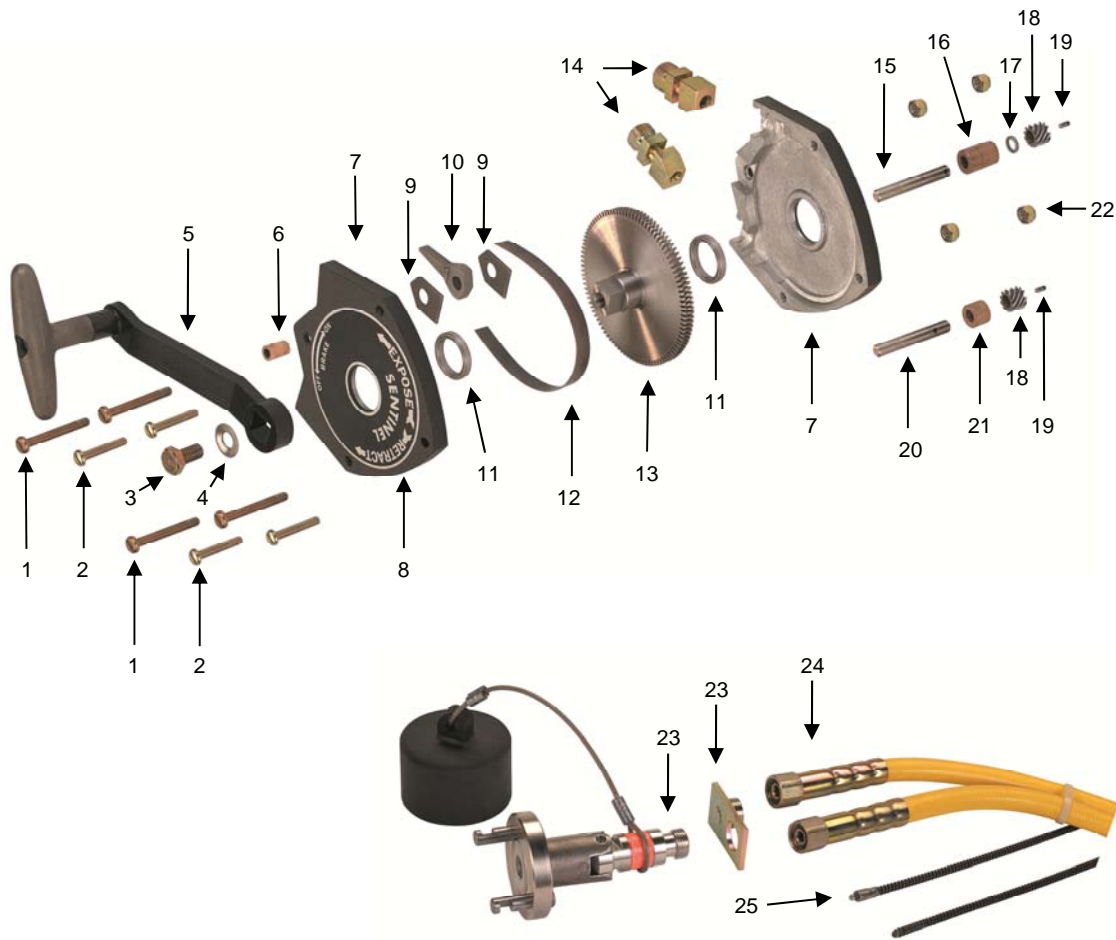

### REMOTE CONTROL HAND CRANK ASSEMBLIES Model Numbers: 882 and 885 series

Item	Part No.	Qty.	Description
1	95008	1	Crank Arm Assembly
2	SCR219-03	1	5/16-18 UNC x 3/4 Hex Head Screw
3	WSH045	1	0.75 OD x 0.313 ID x 0.051-.080 Thick SST Flat Washer
4	95006-01	1	SAN882 Label
5	RIN024	1	15mm Seal
6	95002-6	1	Drive Gear Cover
7	RIN026	1	3 x 96 mm ID O-Ring
8	BBS032	2	15 x 28 x 7 mm Ball Bearing
9	95005	1	Drive Gear Weldment
10	95003	1	Molded Grip Handle Body

Item	Part No.	Qty.	Description
11	95003-6	6	Tubular Spacer
12	WSH047	6	Flat Washer
13	SCR252	6	6/32 x 7/8 SST Socket Head Screw
14	66103	1	Connecting Plug Assembly
15	95039	1	Plug Conduit End
16	95037-2	1	Clamp, Bottom Half
17	95037-1	1	Clamp, Top Half
18	95050-XX	1	Drive Cable Assembly XX-Long
19	95038	1	Spring Duplex Strain Relief
20	95035-XX	1	Conduit Assembly, Extreme Control, XX-Long

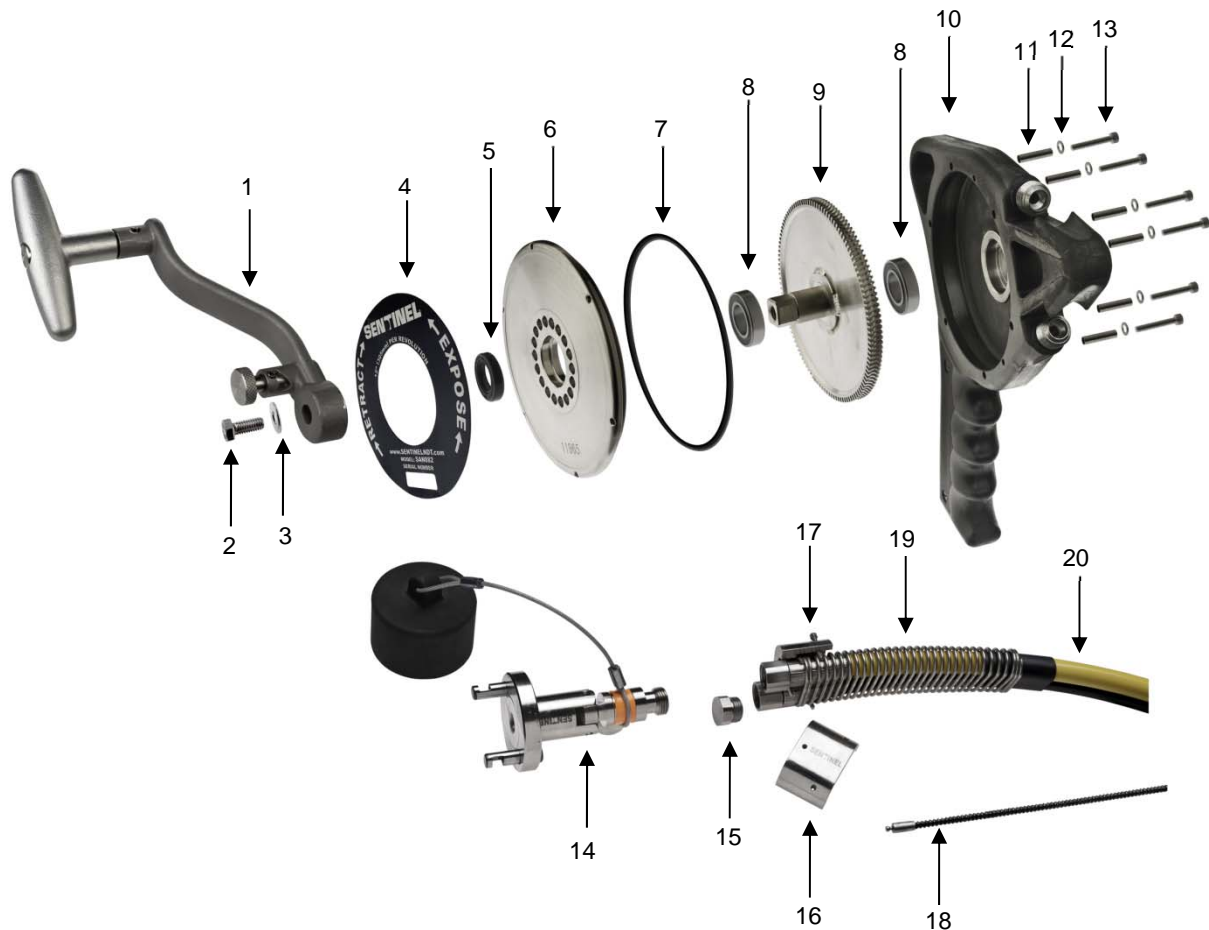

### REMOTE CONTROL ASSEMBLIES Model numbers: 882 and 885 series



### SOURCE GUIDE TUBES Model numbers: 95020 and 95021



COMPONENTS FOR: Model 664 reel, odometer for Model 664 reel, Model 692 hand crank, Model 693 hand crank

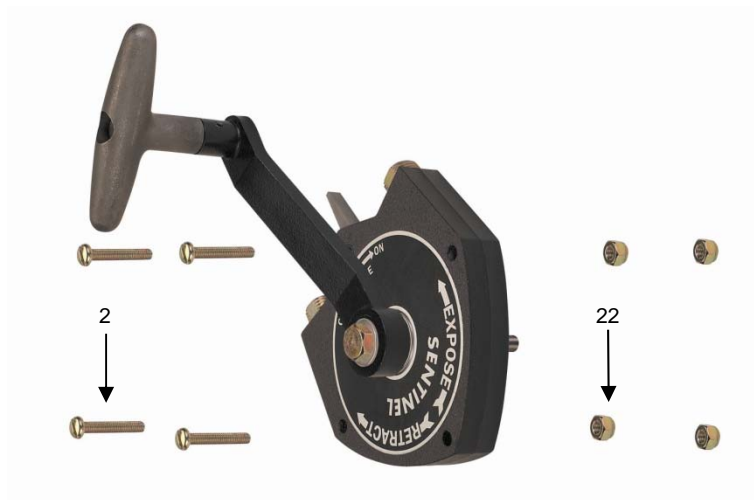

The following instructions are samples for the transport of this radiographic exposure device/transport container and source assembly within the United States and are based on current transport regulations. Shippers of radioactive materials in regulatory jurisdictions outside the USA must ensure full compliance with all current and applicable transport regulations. Listed are the regulations that should be referenced for the legal transport of radioactive materials:

- International Atomic Energy Agency requirements No. TS-R-1 (2009 Edition), 'Regulations for the Safe Transport of Radioactive Materials' and the IAEA 'Code of Conduct on the Safety and Security of Radioactive Sources' - IAEACODEOC/2004.
- International Air Transport Association, 'Dangerous Goods Regulations'.
- International Civil Aviation Organization, 'Technical Instructions for the Safe Transport of Dangerous Goods by Air'.
- International Maritime Organization, 'International Maritime Dangerous Goods Code'.
- U.S. Department of Transportation, Title 49 Code of Federal Regulations Parts 171 through 178.
- U.S. Nuclear Regulatory Commission, Title 10, Code of Federal Regulations, Parts 20, 34 & 71.
- Canadian Nuclear Safety Commission, Nuclear Safety and Control Act, 'Packaging and Transport of Nuclear Substances Regulations'; 'Nuclear Substances and Radiation Devices Regulations'.
- Transport Canada, 'Transport of Dangerous Goods Regulations'.
- Transport in the United Kingdom: Refer to the regulations as listed on the ADR approval Certificate.

### Transport Package

The Model 880 Delta, 880 Sigma, 880 Elite, 880 Omega and 880 Atlas are approved as radiographic exposure devices. All but the Model 880 Omega and Model 880 Atlas are approved as Type B (U)-96 transport packages under the certification number USA/9296/B(U)-96. The Model 880 Omega and the Model 880 Atlas are approved as Type A transport packages.

As a shipper of radioactive material, you must perform a pre-shipment inspection to verify conformance to the Type B(U)-96 certification (or Type A approval as applicable) for each individual shipment of radioactive material. This verification assures the package's integrity is not compromised, which may cause a reduction of safety while in the transport system.

Visually inspect the transport package:

- Assure the source assembly is properly secured in the locked position. The selector ring must be in the LOCK position, the protective cover in place, the plunger lock engaged and the key removed.
- Assure all screws are present and secured.
- Assure the front port is properly secured.
- Assure the seal wire is properly installed, if used.
- Assure the 'Danger, Radioactive Material' label is securely attached and visible on the package. Assure that the label is legible and not defaced.
- Assure the other information on the label is legible (the warnings and trefoil, the model number and serial number and either the Type B certification number or the Type A specification identification as applicable).
- Visually assure all welded areas are not cracked. If there is any evidence of cracked welds contact QSA Global, Inc. prior to shipment.
- Assure all the conditions of the Certificate of Compliance are met and the transport package has all the required markings.
- Wipe test the transport package over an area of 300 cm<sup>2</sup> and assure the level of removable contamination is less than 0.0001 µCi per cm<sup>2</sup>.

**If the package fails any of the inspections described, remove the container from use until it can be brought into compliance with the Type B (U) certificate or the Type A approval as appropriate.**

## Receipt of Radioactive Material

### NOTE

- 1 A radioactive material package must be accepted from the carrier at the time it is delivered. [10CFR20.1906(a)(1)]
- 2 If a radioactive material package is to be held at the carrier's terminal for pickup, arrangements must be made to receive notification from the carrier of the arrival of the package at the time of arrival. The package must be picked up expeditiously upon receipt of notification (within three hours if practicable). [10CFR20.1906(c), Reg. Guide 7.3-5]
- 3 Monitoring as described below must be performed as soon as practicable but at least within three hours if received during normal working hours or within three hours of the next work day if received after normal working hours. [10CFR20.1906]
- 3.a Upon receipt of a package of radioactive material, the package shall be placed in a restricted area. Assure appropriate personnel are notified.
- 3.b Survey the entire exterior surface of the package at the time of receipt and assure that the maximum radiation level does not exceed 2 mSv/hr (200 mRem/hr). Survey all sides of the device at 1m from the exterior surfaces of the packages and assure that the maximum radiation level does not exceed 0.1 mSv/hr (10 mRem/hr). If either of these limits are exceeded, notify the Radiation Safety Officer immediately. Record the maximum radiation levels measured at the package surface and at 1m from the package surface on the Receiving Report. [10CFR20.1906(d), 10CFR71.47]

**Note: If any of these limits are exceeded, the Radiation Safety Officer must immediately notify the USNRC (or applicable governing agency) and the final delivering carrier.**

- 4 Inspect the package for any evidence of physical damage. Record the results of this inspection on the Receiving Report. Also record on the Receiving Report the date, source model number, source serial number, radionuclide, activity, the individuals name making the record, transport package model number, mass or activity of the depleted uranium and the package serial number. [10CFR34.63]
- 5 Assure that the package is locked or place the package into an outer locked container and secure the package in accordance with your license requirements. [10CFR34.35, 10CFR34.23]
- 6 Keep a copy of the Operating Manual for the package on file to assure you have the proper opening and handling instructions. Assure that the instructions are followed and any noted special precautions are performed. [10CFR20.1906(e)]

**Note: For licensees transporting special form sources in licensee owned or operated vehicles to and from a work site are exempt from the contamination monitoring requirements. The radiation survey required upon receipt must still be performed. [10CFR20.1906(f)]**

- 7 If you are receiving a nationally tracked source (Category 1 or 2 quantities) from another licensee, complete the report: USNRC form 748 and submit the report by the close of the next business day after the transaction. [10 CFR 20.2207 and appendix E]. Some regulatory jurisdictions require reporting of depleted Uranium shielding of the transport container in addition to the radioactive materials. Verify current national regulatory and security requirements to ensure compliance.





### Shipment of Radioactive Material

1 Prior to shipment of a Type B package within the USA, assure that you are a registered user of the radioactive material package you wish to ship. Also, assure that you have appropriate quality assurance procedures for Type B packages. [10CFR71.12, 10CFR34.31(b)]

2 Pre-shipment training requirements:

Prior to shipping hazardous materials, personnel must be trained in accordance with 49CFR172, Subpart H and be retrained every three years. Training shall include:

- General awareness/familiarization training.
- Function specific training.
- Safety training, providing:
  - Emergency response information.
  - Measures to protect employees from potential hazards associated with hazardous material to which employees may be exposed in the workplace, both radioactive and chemical hazards.
  - Employer safety measures implemented to protect employees.
  - Methods and procedures for accident avoidance, i.e. proper procedures for handling hazardous material packages.
  - OSHA or EPA training, MSDS information.
  - Transportation security training for organizations that are required to have a security plan. Haz-Mat employees must be trained in the security plan and its implementation including awareness of security risks and how to recognize and respond to security threats. [49CFR172.800, 10CFR30, IAEA CODEOC/2004 ]
  - If shipments involves use of a Declaration of Dangerous Good form, all personnel involved with the shipment must be trained in IATA/ICAO/IAEA requirements every two years.

An appropriate test must be administered and the following documentation must be kept:

- Employee name.
- Date of most recent training.
- Description, copy or location of the training methods.
- Name of person performing training.
- Certification that person has been trained and tested.

Documentation should be kept in one file, i.e. all radiation safety related training used as part of the Hazmat training should be included.

3 Prior to shipment maintain copies on file of the most current Type B (U) and Special Form certifications (or Type A approval as applicable) and assure the package and its contents meet the following requirements:



- The radioactive contents and form are authorized for use in the package.
- The package is in good physical condition for transport.
- All locks and outlet port fittings are properly installed and seal wired where required.
- All conditions of the Type B(U)-96 Certificate of Compliance (or Type A approval as appropriate) are met [10CFR71.87]. Maintain copies of the current Type B (U), Type A and special form certifications on file. Current copies must also include the applicable drawings.

4 Assure that the source is secured in the proper shielded position in the shipping package as described in Section 2 of this operations manual. Perform a pre-shipment inspection as described in Section 5 under the "Transport Package" requirements and verify the package is assembled as described in the Type B(U) certification (or Type A approval as applicable).

- 5 As applicable, attach a security seal with an identification mark to the package closure that serves as a tamper indicator. [49CFR173.412(a)]
- 6 If the shipping package is to be packaged inside a crate or other outer packaging, the outer packaging must be strong enough to withstand the normal conditions of transport and must not reduce the safety of the package. The shipping package must be placed within the outer package with sufficient blocking to prevent shifting during transportation. [49CFR173.25]
- 7 Survey the entire exterior surfaces of the package and assure that the maximum radiation level does not exceed 2 mSv/hr (200 mRem/hr). Survey 1 m from all sides of the exterior surfaces of the package and assure that the maximum radiation level does not exceed 0.1 mSv/hr (10 mRem/hr). Determine the proper shipping labels to be applied to the package using the criteria of Table 1. [49CFR172.403]

**Note: If shipping the container inside an overpack or convenience box in the back of a vehicle, survey and label both the inner 880 package and the overpack. Placarding the vehicle is dependent on the category of label applied to the overpack if used. [49CFR173.448]**

**Table 1**

	<b>Maximum Radiation Level at Surface</b>	<b>Maximum Radiation Level at 1 Meter</b>
<b>Radioactive White I</b> 	<b>0.5 mRem/hr (0.005 mSv/hr)</b>	<b>None</b>
<b>Radioactive Yellow II</b> 	<b>50 mRem/hr (0.5 mSv/hr)</b>	<b>1.0 mRem/hr (0.01 mSv/hr)</b>
<b>Radioactive Yellow III</b> 	<b>200 mRem/hr (2 mSv/hr)</b>	<b>10 mRem/hr (0.1 mSv/hr)</b>

**For a package, both the transport index (TI) and the surface radiation level conditions shall be taken into account in determining which is the appropriate category of radioactive material label. Where the TI satisfies the condition for one category but the surface radiation level satisfies the condition for a different category, the package shall be assigned to the higher category of the two. For this purpose, category White-I shall be regarded as the lowest category.**

The TI is the maximum radiation level measured in mRem/hr at a distance of 1m from the external surfaces of the package. When recording the TI, the dose rate units of mRem/hr are not listed, for example a reading of 20 µSv/hr (2 mem/hr) would indicate a TI = 2.0. (Note that the TI is rounded to the nearest tenth value.)

- 8 Properly complete two shipping labels indicating the contents (e.g. Ir-192), the activity of the source (in Becquerels or multiples of Becquerels, e.g. GigaBecquerels (GBq)) and the transport index. The transport index is used only on Yellow II and Yellow III labels and is defined as the maximum radiation level in mRem/hr at 1m from the package surface (see Table 1). [49CFR172.403(g)]
- 9 Assure that any old shipping labels have been removed from the package. Apply two properly completed labels to two opposite sides of the package (excluding the bottom surface). [49CFR172.403(f)]
- 10 For air shipments within the USA, the package must be labeled with '**Cargo aircraft only**' labels. Ensure that these labels do not cover any other package markings or labels.
- 11 Mark the outside of the package with the proper shipping name and identification number (e.g., 'Radioactive Material, Type B(U) Package, UN2916' for a Type B(U) shipment or 'Radioactive Material, Type A Package, Special Form, UN3332' for a Type A shipment) if not already marked. Place the letters RQ (stands for Reportable Quantity) next to the proper shipping name when shipping more than 10 Ci (370 GBq) of Ir-192, Se-75, Yb-169, Co-60 or 1 Ci (37 GBq) of Cs-137. [49CFR172.300]

Description	Proper Shipping Name
Type B (U) package containing a special form source	Radioactive Material, Type B(U) Package UN 2916
Type A package containing a special form source	Radioactive Material, Type A Package Special Form UN 3332
Type A package containing a non special form source	Radioactive Material, Type A Package UN 2915

- 12 If the shipping package is inside a crate or other outer packaging, mark the outside package with '**RQ**' (if applicable), the '**UN Identification Number**', followed by the '**proper shipping name**'. The word '**OVERPACK**' must be marked on the outside package. The required markings must be in letters a minimum of ½ inch (13 mm) high. [49CFR172.310; 49CFR173.471; 49CFR173.25]

**Note: If shipping a Type A quantity of an isotope in a Type B (U) package that is not approved for that isotope, i.e. a sealed source assembly with a milliCurie quantity of Co-60 in a Type B (U) source changer, the Type B (U) container labels must be covered with the appropriate Type A container information.**

- 13 Assure that the levels of removable radioactive contamination on the outside surface of the outer package do not exceed 0.37Bq ( $10^{-5}$  µCi) per cm<sup>2</sup>. [49CFR173.443]
- 14 If the package gross weight exceeds 110 lb (50 kg), mark the outside of the package with the gross weight. [IATA 10.7.1.3.1]

**15** Properly complete the shipping papers indicating:

- a. United Nations identification number, Proper shipping name, Class Number '7', and (e.g. 'Radioactive Material, Type B(U) Package, Class 7, UN2916' for a Type B (U) shipment or 'Radioactive Material, Type A Package, Special Form, UN3332' for a Type A shipment).
- b. The letters RQ must appear before or after the proper shipping name when shipping more than 10 Ci (370 GBq) of Ir-192, Se-75, Yb-169, Co-60 or 1 Ci (37 GBq) of Cs-137.
- c. Name of the radionuclide (e.g., Iridium-192, Selenium-75, Cobalt-60, Cesium-137).
- d. Physical and chemical form (i.e. Special Form).
- e. Activity of the source in Becquerels or other appropriate multiples of Becquerels on the DOT label and the shipping papers. Note: number of Curies x 37 = number of GigaBecquerels (GBq).
- f. Category of label applied (i.e. Radioactive Yellow II).
- g. Transport Index.
- h. USNRC identification number (i.e. USA/9296/B(U)-96) (or DOT Type A Specification 7A for a Type A shipment).
- i. For export shipments, the IAEA identification number (i.e. USA/9296/B(U)-96).  
For Canadian export shipments only: include the Canadian Endorsement Number (CDN/E199/-96) for a source activities greater than an A1 value in a Type B(U) package or as Type A as applicable.
- j. Shipper's certification: **'This is to certify that the above-named materials are properly classified, described, packaged, marked and labeled and are in proper condition for transport according to the applicable regulations of the Department of Transportation.'** [49 CFR 172.204(a)].

**NOTE:** For shipments in company vehicles to and from job sites within the USA, the shipper's certification is not required.

- k. The shipping papers must indicate your company's emergency telephone number. The telephone number must have 24-hour coverage in case of an emergency concerning your shipment. The telephone number must be clearly visible on the shipping paper and must be answered by a person that can provide immediate emergency response information. Beepers and pagers are not acceptable.

**16** For air shipments, the shipping papers must meet the requirements specified in IATA for a Shipper's Declaration for Dangerous Goods. In addition to the information listed in Step 15 of this part, the following information needs to be specified:

- a. Air waybill number: Enter the number of the air waybill to which the declaration form will be attached. (This may be amended by the carrier.)
- b. Aircraft limitations: Specify that the shipment is within the limitations for 'Cargo aircraft only.' A notation can be added in the handling information box of the Shipper's Declaration which states 'This shipment may be carried on passenger aircraft outside U.S. jurisdiction'.
- c. Airport of departure: Enter the full name of the airport or city of departure, which may be amended by the carrier.
- d. Airport of destination: Enter the full name of the airport or city of destination, which may be amended by the carrier.
- e. Shipment type: Specify the shipment type as 'Radioactive'.
- f. Under quantity and type of dangerous goods, specify the number of packages (of same type and content), their type of package and activity in Becquerels or multiples thereof (units used must be clearly indicated) in each package, including packages in overpacks.

(If relevant) Indication of use of overpack and dimensions of the overpack (including dimensional units). When an overpack is used, the wording **'Overpack used'** must be inserted on the declaration form immediately after all the relevant entries relating to the packages within the overpack. In such cases, packages within overpacks must be listed first. Dimension units must be in sub-multiples of meters.

- g. The 24-hour emergency number required by Step 15 of this part, must appear in the 'Additional Handling Information' section of the Declaration for Dangerous Goods.  
For air shipments within the USA, the following statement must be included:  
**"This shipment is within the limitations prescribed for cargo aircraft only."**
- h. For shipment of special form radioactive material, the Special Form Certificate of Competent Authority for the radioactive source must be included. (e.g. USA/0335/S). For shipment of Type B (U) packages also include the certificate of Competent Authority (e.g. USA/9296/B(U)-96)
- i. The shipper's certification must be as follows:

'I hereby certify that the contents of this consignment are fully and accurately described above by the proper shipping name, and are classified, packaged, marked and labeled/placarded, and are in all respects in proper condition for transport according to applicable International and National governmental regulations. I declare that all of the applicable air transport requirements have been met.'

The information on the Declaration for Dangerous Goods must be entered strictly in accordance with the order specified in the latest edition of the International Air Transport Association, Dangerous Goods Regulations. Questions regarding completion of a Shipper's Declaration for Dangerous Goods should be directed to the Radiation Safety Officer.

If you are shipping a nationally tracked source (Category 1 or 2 quantities) to another licensed recipient, complete the report: USNRC form 748 and submit the report by the close of the next business day after the transaction. [10 CFR 20.2207 and appendix E, IAEA CODEOC/2004]. Some regulatory jurisdictions require reporting of depleted Uranium (DU) shielding of the transport container in addition to the radioactive materials. Verify current national regulatory and security requirements to ensure compliance.

### Shipment of Empty Uranium Shielded Containers

- 1 Assure that the package does not contain a radioactive source. Perform the following procedure to confirm there are no unauthorized source assemblies within the container:
  - Transfer the authorized source assembly from the exposure device in accordance with the source changer operations manual.
  - After removing the source assembly and disconnecting the source assembly, attach the jumper (dummy connector without a serial number) to the male connector of the control cable.
  - Retract the control cable and jumper and disconnect the controls from the locking mechanism.
  - Insert the protective cover into the locking mechanism, rotate the selector ring into the lock position, engage the plunger lock and remove key. Remove the source guide tube and close the outlet port cover.
  - Remove the source identification tag from the exposure device and place it with the source assembly.
  - In some regulatory jurisdictions, 'empty' labels or tags must be attached to the empty Model 880.
- 2 If the shipping package is to be placed inside a crate or other outer packaging, the outer packaging must be strong enough to withstand the normal conditions of transport and must not reduce the safety of the package. The shipping package must be placed within the outer package with sufficient blocking to prevent shifting during transportation. [49CFR173.25]
- 3 Assure that the levels of removable radioactive contamination on the outside surface of the outer package does not exceed 0.4 Bq ( $10^{-5}$   $\mu$ Ci) per  $\text{cm}^2$  based on wiping an area of at least  $300 \text{ cm}^2$  [49CFR173.443]
- 4 Survey the package at the surface and at one meter from the surface to determine the proper shipping labels to be applied to the package.

**Note:** If the surface radiation level does not exceed 5  $\mu$ Sv/hr (0.5 mRem/hr) and there is no measurable radiation level at 1m from the surface, continue with the instructions in Step 5 below and skip Step 6. If either of these levels are exceeded, skip Step 5 and continue with the instructions in Step 6.

- 5 If the surface radiation level does not exceed 5  $\mu$ Sv/hr (0.5mRem/hr) and there is no measurable radiation level at one meter from the surface, no label is required.
  - a. The outside of the inner packaging or, if there is no inner packaging, the outside of the packaging itself bears the marking 'Radioactive'.
  - b. The outside of the package must be marked with UN2909.
  - c. When shipping by air, excepted packages are exempt from the requirement for use of Dangerous Goods Declaration.
    - i. For air shipments [IATA 10.8.8.3], the 'Quantity and Type of Dangerous Goods' box must read:

"Radioactive Material, excepted package, articles manufactured from depleted uranium, UN2909."

- ii. Required after 1 January 2007, the outside of the package must include the following label [IATA 10.7.4.4.3]:

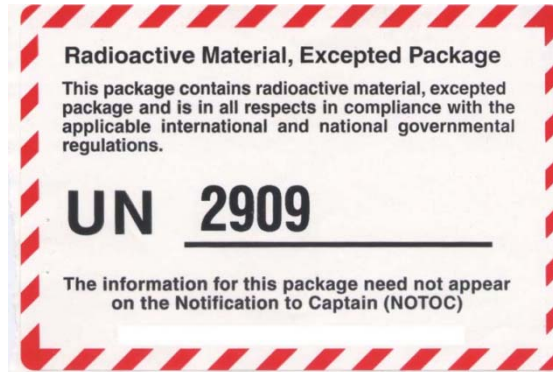

- 6 If the surface radiation level exceeds 5  $\mu\text{Sv/hr}$  (0.5 mRem/hr), or if there is a measurable radiation level at 1m from the surface, use the criteria of Table 1 to determine the proper shipping labels to be applied to the package.
    - a. Mark the outside of the outer shipping package with the proper shipping name and identification number: **Radioactive Material, Low Specific Activity (LSA-I) UN2912, Class 7**. If the container is packaged inside a crate or other outer packaging, mark the outer package with the word '**Overpack**'.
    - b. Properly complete the shipping papers, indicating:
      - i. Proper shipping name, identification number and class (i.e. Radioactive Material, Low Specific Activity (LSA-I), Class 7, UN2912).
      - ii. Name of the radionuclide (i.e. depleted Uranium-238).
      - iii. Physical and chemical form (i.e. Solid Metal).
      - iv. Activity of the uranium in Becquerels or other appropriate multiples of Becquerels.
- NOTE:** Number of Curies x 37,000 = number of MegaBecquerels (MBq). The activity in millicuries for U-238 equals 0.16 x the shield weight in pounds (i.e. for a Model 880 Delta with a 34 lb shield, the approximate activity is 0.16 x 34 lb = 5.4 mCi).
- v. Category of label applied (i.e. Radioactive Yellow II).
  - vi. Transport Index.
  - vii. USNRC identification number or DOT specification number, i.e. Model 880 Series cert: USA/9296/B(U)-96.
  - viii. Shipper's certification:

**'This is to certify that the above-named materials are properly classified, described, packaged, marked and labeled and are in proper condition for transport according to the applicable regulations of the Department of Transportation.'** [49CFR172.204(a)]

Note: For shipments in company vehicles to and from job sites, the shipper's certification is not required.

For air shipments, the following Shipper's Certification may be used:

**'I hereby certify that the contents of this consignment are fully and accurately described above by proper shipping name and are classified, packaged, marked and labeled/placarded, and are in all respects in proper condition for transport according to applicable International and national governmental regulations. I declare that all of the applicable air transport requirements have been met'**

- ix. For air shipments, the package must be labeled with a '**Cargo aircraft only**' label and the shipping papers must state: '**This shipment is within the limitations prescribed for cargo only aircraft**'.
  - x. Your company's 24-hour emergency telephone number.
  - xi. The weight of the package including the unit of measurement of the hazardous material covered by the description (e.g. 100 lb. Note: For air shipments, the weight must be in multiples of kilograms.)
- c. For air shipments, the shipping papers must meet the requirements specified in IATA for a Shipper's Declaration for Dangerous Goods. In addition to the information listed in this Section, the following information needs to be specified:
- i. Air waybill number: Enter the number of the air waybill to which the declaration form will be attached. (This may be amended by the carrier.)
  - ii. Aircraft limitations: Specify that the shipment is within the limitations for '**Cargo aircraft only**.' A notation can be added in the handling information box of the Shipper's Declaration, which states '**This shipment may be carried on passenger aircraft outside U.S. jurisdiction**'.
  - iii. Airport of departure: Enter the full name of the airport or city of departure, which may be amended by the carrier.
  - iv. Airport of destination: Enter the full name of the airport or city of destination, which may be amended by the carrier.
  - v. Specify contents (isotope) on the DOT hazard labels as LSA-I.
  - vi. Shipment Type: Specify the shipment type as 'Radioactive'.
  - vii. Under Quantity and Type of Dangerous Goods, specify the number of packages (of same type and content), their type of packaging and activity in Becquerels or multiples thereof (units used must be clearly indicated) in each package, including packages in overpacks that are labeled as LSA-I.

(If relevant) Indication of use of overpack and dimensions of the overpack (including dimensional units). When an overpack is used, the wording 'Overpack' must be inserted on the declaration form immediately after all the relevant entries relating to the packages within the overpack. In such cases, packages within overpacks must be listed first. Dimension units must be in sub-multiples of meters.

- viii. The 24-hour emergency number required in this Section, must appear in the 'Additional Handling Information' section of the Declaration for Dangerous Goods.

The information on the Declaration for Dangerous Goods must be entered strictly in accordance with the order specified in the latest edition of the International Air Transport Association, Dangerous Goods Regulations. Questions regarding completion of a Shipper's Declaration for Dangerous Goods should be directed to the Radiation Safety Officer [49 CFR 172.402(b); 49 CFR 172.204(c)]



**Carriage of Radioactive Material**

- 1 Assure that the vehicle used is in good condition and carries the normal complement of safety equipment including Radiation Area signs, a length of rope, spare tire, fire extinguisher, a set of vehicle tools and a set of flares. Assure that the glove compartment contains the vehicle registration certification and an operating flashlight. Additionally, assure that the operator has a calibrated and operable survey meter and assure that all individuals traveling in the vehicle are wearing both a film badge and a direct reading pocket dosimeter.
- 2 Assure that the transport package is properly packaged, marked and labeled and assure that the proper shipping papers are completed in accordance with the instructions for shipping radioactive material. The shipping papers must be accessible from the driver's seat.
- 3 Place the transport package in the vehicle. Properly brace and secure the package against movement in the vehicle. [49CFR177.842(d)]
- 4 Survey the driver's compartment to assure that the radiation level does not exceed 0.02 mSv/hr (2 mRem/hr). [49CFR177.842(g)] Note: This requirement is mandatory only for exclusive use shipments by a common carrier. [49CFR173.441(b)(4)]
- 5 If the vehicle is transporting a package bearing a Radioactive Yellow III label, the vehicle must be placarded on all four sides with a Radioactive placard.

**Note:** Operation of a vehicle which is required to be placarded requires compliance with the Federal Motor Carrier Safety Regulations of 49CFR Parts 390-397 and the Driver Training requirements of 49CFR177.827; 49CFR177.804.

- 6 Complete the Radioactive Material Transport Checklist (see attached example). Forward a completed copy to the Radiation Safety Officer upon completion of the carriage.
- 7 If the vehicle becomes disabled on the road, do not leave the vehicle unguarded when going for help. A message for help may be sent by a passing motorist or the police may be enlisted to guard the vehicle.
- 8 Should any kind of accident occur, make an immediate radiation survey to determine if any radiation levels are unusually high. If unusual radiation levels exist, establish the boundary of the restricted area. Keep all persons out of this area and get police assistance, if possible. Notify the Radiation Safety Officer as soon as possible, but do not leave the scene without assuring that the police or some other responsible party will keep people out of the area.
- 9 Collect information pertinent to the accident, such as names of witnesses, names of people involved, and names of police, license numbers and circumstances of the accident. Call the Radiation Safety Officer promptly and give him as much information as possible.
- 10 If a source should escape from the packaging, the vehicle operator should make no attempt to restore the source by himself. He should wait for assistance from the Radiation Safety Officer.
- 11 If the vehicle is going to be used for storage of radioactive material at a temporary job site:
  - a. The vehicle's storage access entrance must be posted with 'Caution Radioactive Material' signs.
  - b. The vehicle must be secured/locked so that there is no unauthorized access.
  - c. Radiation levels must be below 20  $\mu$ Sv/hr (2 mR/hr) outside the vehicle to meet unrestricted area requirements.
  - d. Vehicle must meet new security requirements where applicable.

- 12** In the event of a transport emergency or accident involving this package, follow the guidance contained in “2004 Emergency Response Guidebook: A Guidebook for First Responders During the Initial Phase of a Dangerous Goods/Hazardous Materials Incident”, or equivalent guidance documentation.

**13 Security during transport in company vehicles:**

Whenever portable and mobile radiographic exposure devices are removed from the permanent facility's approved storage area and placed into the transportation system, company trustworthy and reliable (T&R) employees that have been Haz-Mat trained will perform the following security duties during transport of radioactive materials:

- a. After the radioactive material package is prepared in accordance to current transport regulations, the package must be secured and locked in the designated area of the transport vehicle. The door to the storage area of the vehicle is closed locked to prevent unauthorized access to the darkroom during transport from the facility to the job-site. Shipping or receiving radioactive materials shall be accomplished in a designated area of the permanent facility.
- b. While containing radioactive material packages, the vehicle is also a temporary storage area (whenever the package is not under continuous, direct surveillance by a T&R employee). The package must be locked in the vehicle as described above and the driver / passenger doors of the vehicle are to be locked. The alarm system and the transport vehicle disabling devices are activated.
- c. Whenever the transport vehicle is stopped for refueling, coffee stops, etc. the ignition keys are removed from the vehicle. If the T&R employee(s) leave the vehicle unattended, the vehicle must be completely locked and alarmed as described above.
- d. During transport to and from job-sites, T&R employees informed to:
  - Minimize the number of vehicle stops for fueling, beverages, meals, etc to minimize exposure to security risks.
  - Do not engage in any conversation with strangers concerning vehicle contents or job-site destinations.
  - Be aware of their surroundings and the people during stops, a car-jacking usually takes place at traffic lights.
  - Know what action is required under the security plan by the T&R employee if a car on the highway is following them, photographing their truck, if the truck is disabled on a highway, if the truck was involved in an accident and cannot be driven away.
  - Know what immediate response is required by a T&R employee if the vehicle is stolen or the radioactive material package is lost or stolen.
  - Have the ability to communicate immediately with the Trustworthy and Reliable Official (TRO) should they need assistance or have a security related question.
  - Know to report immediately to the TRO if an unauthorized party attempts to steal or gain access to the radioactive material being transported.
  - Know what actions are required if the vehicle's alarm is triggered while parked, indicating an attempted intrusion.

- Know that all T&R employees are to safeguard all transport security documents and information regarding shipments of RAM from unauthorized disclosure.
- Know that whenever the radioactive materials are removed from the transport vehicle at the job-site, the radioactive material must be under continuous, direct surveillance by the T&R employees until it is returned to the designated area of the transport vehicle.
- Know the purpose and reason for the increased security requirements of the USNRC, USDOT and Department of Homeland Security agencies.

T&R employees returning from job-sites will unload the radioactive material from the transport vehicle. They will secure the radioactive material in the facility's designated storage area and activate the storage area's security alarm system.

### Radioactive material transport checklist

Date \_\_\_\_\_ Operator \_\_\_\_\_

Destination \_\_\_\_\_

Transport Container Model \_\_\_\_\_ Serial Number \_\_\_\_\_

Radionuclide \_\_\_\_\_ Activity \_\_\_\_\_

Type of Label Applied \_\_\_\_\_ Transport Index \_\_\_\_\_

Survey Meter Model \_\_\_\_\_ Serial Number \_\_\_\_\_

Calibration Date \_\_\_\_\_ Film Badge \_\_\_\_\_

Dosimeter Serial Number \_\_\_\_\_ Initial Reading \_\_\_\_\_

Final Reading \_\_\_\_\_

Radiation Area Signs \_\_\_\_\_ Packing List \_\_\_\_\_

Rope \_\_\_\_\_ Bill of Lading \_\_\_\_\_

Radioactive Material Sign \_\_\_\_\_ Emergency Equipment \_\_\_\_\_

Radiation Survey \_\_\_\_\_ Driver's Compartment \_\_\_\_\_ mRem/hr

(Record highest reading) Vehicle (18 in from surface) \_\_\_\_\_ mRem/hr

Packages properly marked and labeled (including transport index) \_\_\_\_\_

Packages secured in vehicle \_\_\_\_\_ Vehicle Placarded \_\_\_\_\_

Shipping papers properly completed \_\_\_\_\_

Remarks: \_\_\_\_\_

\_\_\_\_\_

\_\_\_\_\_

\_\_\_\_\_

Operator's Signature \_\_\_\_\_

**Area alarm**

An area radiation level monitor that provides a highly visual warning when the radiation level exceeds a pre-set threshold. Commonly referred to as Gammalarms, use is required by most jurisdictions in permanent radiographic installations and they are often used in conjunction with door interlocks and audible alarms. Portable area alarms are required by some jurisdictions for radiography performed at temporary job-sites.

**Alarm ratemeter**

An alarm worn by radiography personnel that provides a continuous audible warning when the alarm ratemeter detects a radiation level in excess of a pre-set threshold of 5mSv/hr (500mR/hr). This redundant safety alarm is required by regulation for temporary job-site radiography within the USA.

**Apparatus for industrial gamma radiography**

Apparatus including an exposure device, a source assembly as applicable, a remote control, a projection sheath, an exposure head and accessories designed to enable radiation emitted by a sealed radioactive source to be used for industrial gamma radiography purposes. Also known as: isotope radiography system, isotope radiography kit.

**Automatic securing mechanism**

An automatically activated mechanism located on the radiographic exposure device designed to restrict the source assembly in the secured position.

**Beam limiter**

A shielding device for confining the elements of a beam of radiation to an assigned solid angle. Beam limiters are generally manufactured from lead, tungsten and depleted Uranium and are pre-positioned over/on the radiation source's working position. Also known as: collimators.

**Control crank**

A control cable cranking device that is a component of the remote controls. The control crank is used at a distance by the radiography personnel to move the radiation source to and from the device, through projection sheaths to and from the exposure position. Manual control crank mechanisms are commonly used, but automatic exposure controllers are available which can be operated from a greater distance and allows preset timing and automatic expose and retract modes. Also known as: wind-outs, crank-outs and hand-cranks.

**Control cable**

A cable or other mechanical means used to project and retract the source assembly out from and into the radiographic exposure device by means of remote control. The control cable includes the means of attachment to the source holder. Also known as: remote control cable, drive cable, Teleflex™ cable.

**Control cable sheath**

Rigid or flexible tube for guiding the control cable from the remote to the radiographic exposure device and providing physical protection to the control cable. The control cable sheath includes the necessary connections for attachment to the radiographic exposure device and to the remote control. Also known as: control cable housing, conduit.

**Exposure device (container)**

Radiographic exposure devices are used to remotely project the radiation source to a predetermined exposure position when required and to securely maintain it and shield it when it is not in use. Current equipment requirements require devices be designed and tested to ISO/ANSI standards and pertinent transportation regulations for transport containers. Also known as: projector, gamma ray projector (G.R.P.), camera, pill-box, source-box, exposure container.

**Exposure head**

Device which locates the sealed source included in the source assembly, in the selected working position and prevents the source assembly from projecting out of the projection sheath. Also known as: source stop, end stop, snout and head-hose.

**Locked position**

Describes the condition when the lock on a radiographic exposure device or transport container is fully engaged to lock the source assembly in place and the key is removed from the lock. This condition prevents unauthorized personnel access to the sealed source assembly locked within the device.

**Maximum rating**

The maximum activity expressed in Bequerels and Curies that cannot be exceeded, of a sealed source specified by radionuclide by the manufacturer when contained within a radiographic exposure device or a transport container.

**Plunger lock**

A mechanical device with a key used to lock or unlock the radiographic exposure device or transport container.

**Projection sheath**

A flexible or rigid tube for guiding the source assembly from the radiographic exposure device to the working position, having the necessary connections for attachment to the radiographic exposure device and the exposure head or including the exposure head itself. The projection sheaths also provide protection of the source assembly and attached control cable from water, dirt, sand and other foreign materials usually present at radiography environments. Also known as: source guide tubes, guide tubes, source tubes, head-hoses. Examples of rigid projection sheaths include j-tubes, probes, jet engine probes.

**Remote control**

The mechanical device that enables the source assembly to and from a working position by operation from a distance away from the radiographic exposure device. The remote control includes the control crank mechanism (normally a hand-crank), and where applicable, also the control cable, the control cable sheath and the necessary connections and attachments. See additional description under 'control crank'.

**Reserve sheath**

Remote control sheath (conduit) containing the length of control cable, necessary for the projection of the source assembly.

**Sealed source**

Radioactive source sealed in a capsule or having a bonded cover, the capsule or cover being strong enough to prevent contact with and dispersion of the radioactive material under the conditions of use and wear for which it was designed. Commonly referred to as: the 'source' or the 'pill'.

**Secured position (shielded position)**

Condition of the radiographic exposure device and source assembly, when the sealed source is fully shielded and restricted to this position within the radiographic exposure device.

Note: When in the secured position during radiographic operations, the radiographic exposure device may be unlocked.

**Simulated source**

A sealed source whose structure is such as that of the sealed radioactive source, but not containing any radioactive material. Also known as: mock source, dummy source, phantom source, dummy pill.

**Source assembly**

A source holder with a sealed source attached or included. In cases where the sealed source is directly attached to the control cable without the use of a source holder, the source assembly is the control cable with the sealed source attached. In cases where the sealed source is not attached to the control cable nor included within the source holder, the sealed source is the source assembly.

In the case where a simulated source is attached to or included with a source holder or control cable, this becomes a simulated source assembly.

Flexible type source assemblies are also known as 'pigtailed'. The source assembly is most commonly referred to as the 'source'.

Rigid or chain link type source assemblies are also known as: source rods, source pencils, source trains, source chains.

**Source holder**

A holder or attachment device, by means of which a sealed source or simulated source can be:

- directly included in the radiographic exposure device (category I apparatus - an exposure device in which the source assembly is not removed for exposure).
- fitted at the end of the control cable (category II apparatus - an exposure device from which the source assembly is projected out through a projection sheath to the exposure head for exposure. The exposure is remotely operated.)

Source holders may be an integral part of the source assembly or may be capable of being dismantled for sealed source replacement.

**Source changers**

A lockable Type A or Type B transport container used to transport new sealed source assemblies, exchange them and return depleted sealed source assemblies to the manufacturer. Source changers are also utilized for storage of sealed source assemblies. Also known as: source exchangers, storage containers.

**Working position**

Condition of the exposure container and source assembly when in the position intended for the Performance of industrial gamma radiography.

## Emergencies

During the termination of a radiographic exposure, observation of the survey meter provides an indication of source movement while cranking the remote control handle. After retracting the sealed source into the exposure device, radiographers are required to perform a confirmatory survey of the exposure device, the projection sheaths and beam limiter when used. Performing a confirmatory survey after a radiographic exposure is required by regulation and is the only method that the radiographer should rely on to determine if a source assembly is in the fully shielded position within the exposure device. If the radiographer measures any radiation level that indicates the sealed source is not fully shielded while performing the confirmatory survey, the radiographer must first recognize that problem exists and then follow his company's emergency procedures. Emergency conditions are those problems in which the source assembly cannot be returned to the shielded position by normal means, specifically the remote control crank mechanism. The majority of problems experienced by radiographers are where the source assembly becomes disconnected or when the source assembly becomes jammed in the projection sheath while in an exposed position. The important safety points for radiographers to follow are:

- Always perform a confirmatory survey after each exposure.
- If higher than expected radiation levels are measured, recognize that an emergency exists.
- Follow emergency procedures.
- Do not attempt to retrieve the sealed source. Secure the area and notify the Radiation Safety Officer.

The radiography crew is limited to the following basic steps that must be adhered to under regulations in the USA (verify national regulations for controlled and supervised areas) :

- 1 Immediately leave the area and maintain continuous surveillance of high radiation area.
- 2 Adjust the restricted area boundary to ensure the measured dose/rate is  $< 2$  mR/hr.  
Do not allow anyone into the area.
- 3 Immediately notify the Radiation Safety Officer.
- 4 Do not leave the area unattended under any circumstances. Maintain security of the area until the Radiation Safety Officer arrives at the site.

Do not under any circumstances attempt to retrieve the source. Performing source retrieval is a licensed activity that allows only specially trained RSOs to respond to an emergency. This regulatory requirement is the result of overexposures to radiographers attempting to handle emergency retrievals by themselves.



### **WARNING:**

**An unshielded source must not be picked up or handled at close range under any circumstances. An unshielded source at close range can cause serious injury or death to anyone who is exposed to it, even for a short duration of time.**

## Training

Formal classroom training in radiation safety, supervised hands-on training and certification by an independent certifying organization of radiographers are essential components for radiological safety in isotope radiography and is a regulatory requirement in the United States and Canada.

Sentinel™, QSA Global, Inc. provides radiation safety, inspection & maintenance and retrieval training at the Baton Rouge, Louisiana and Burlington, Massachusetts facilities. On-site training is available by arrangement.



### **Access to Restricted Areas**

The site where radiography is performed must be separated from other work areas by as much distance as possible. If applicable, check for occupation of the areas above and below the radiography site.

Clearly defined boundaries must be set up and warning signs displayed to provide warning and prevent access to the radiography site by unauthorized personnel before any exposure begins.

No one should enter the boundary marking a 'Restricted Area' or 'Controlled Area' without a film badge or TLD, direct reading pocket dosimeter (or electronic pocket dosimeter) and alarm ratemeter (if required).

A pocket 'chirper' alarm is required in some countries to provide radiography personnel with an immediate audible warning of a high radiation intensity.

### **United States Regulations**

'High Radiation Area' signs must be posted where a dose of 1 mSv (100 mRem) could be received in any one hour. The radiographers must provide continuous direct surveillance of the area or when a permanent installation is used, the entrance must be equipped with door interlocks, audible and visual warnings.

'Radiation Area' signs must be posted where dose of 5  $\mu$ Sv (5 mRem) could be received in any one hour.

'Restricted Area' must be identified and posted where a dose of 20  $\mu$ Sv (2 mRem) could be received in any one hour or 1 mSv (100 mRem) in one year.

In practice, the 'Radiation Area' and 'Restricted Area' are combined and identified by the use of a rope barrier. The area is posted with the 'Radiation Area' signs where the maximum dose will not exceed 20  $\mu$ Sv (2 mR) in any one hour or 1 mSv (100 mRem) in a year. The practice of using the 'Radiation Area' sign at the 'Restricted Area' boundary clearly defines why the area has been restricted. Additionally, the trefoil (radiation) symbol provides a visual warning for those individuals who cannot read.

During a radiographic exposure, a calibrated and operable survey meter must be used to confirm the dose rate at the 'Restricted Area' boundary and adjusted if the dose rate exceeds the limit of 20  $\mu$ Sv (2 mRem) in one hour.

During the radiographic exposure, the radiographers must maintain continuous direct surveillance of the 'High Radiation Area' in addition to ensuring that no one enters their posted 'Restricted Area'.

### **EU Regulations**

A 'Controlled Area' must be marked with a barrier at a distance where the radiation intensity will not exceed 7.5  $\mu$ Sv/hr (0.75 mR/hr). The boundary dose rates must be noted and the record kept for 2 years. During radiographic operations, only classified radiation workers are allowed inside this area.

A 'Supervised Area' is defined as the area where the boundary dose rate limit must not exceed 2.5  $\mu$ Sv/hr (0.25 mR/hr). No barriers or notices are required here, but the radiographer must be vigilant to ensure that personnel in this area do not enter the 'Controlled Area'.

### **Personnel Monitoring**

All personnel who enter a 'Restricted' or 'Controlled' area or are present during radiographic operations are required to wear the appropriate personnel monitoring devices as required by the regulatory jurisdiction. These devices can include; film badges; thermoluminescent dosimeters (TLD); optically stimulated luminescence badges; direct reading pocket dosimeters; electronic pocket dosimeters; alarm ratemeters; and audible alarms. Calibrated and operable survey meters must be used to determine radiation levels when conducting radiographic operations.

**Disposal**

By international regulations, radioactive materials that are no longer required must be transferred to a licensed recipient for final disposition. Cobalt-60 source assemblies that have depleted beyond their useful working life may be returned to authorized recipients using a source changer authorized for the specific model source assembly.

Authorized recipients will provide any specific conditions to the shipper as required by regulatory authorities. As a minimum, sources that are transferred for a final disposition must be within a current leak test and properly secured within an authorized package before shipment.

Damaged, cropped, modified or contaminated source assemblies may require special handling and special transport containers. Notify the authorized recipient for specific instructions in these circumstances.

Depleted Uranium (DU) shielded exposure devices that are removed from service due to severe damage, worn through 'S' tubes or decommissioning reasons must be sent to a licensed recipient for final disposition. If the Type B transport status of a damaged exposure device is impaired, the exposure device must be transported without radioactive source assemblies. DU shielded exposure devices sent for final disposition must be properly packaged, surveyed, marked and labeled before placement into the transportation system.

Contact QSA Global, Inc. for assistance in the transfer of DU shielded exposure device for final disposition



## Sales

SENTINEL™  
QSA Global, Inc.  
6765 Langley Drive  
Baton Rouge, Louisiana 70809 USA

Telephone + 1 225 751 5893  
Toll Free + 1 800 225 1383  
Fax + 1 225 756 0365 or  
+ 1 225 751 8082

## Manufacturing

SENTINEL™  
QSA Global, Inc.  
40 North Avenue,  
Burlington, Massachusetts 01803 USA

Telephone + 1 781 272 2000  
Toll Free + 1 800 815 1383  
Fax + 1 781 273 2216

Email: [sales@sentinelndt.com](mailto:sales@sentinelndt.com)  
Website: [www.sentinelndt.com](http://www.sentinelndt.com)



All goods and services are sold subject to the terms and conditions of QSA Global, Inc. A copy of these terms and conditions is available upon request.

SENTINEL™ is a trademark of QSA Global, Inc.

All brand names and product names where used are acknowledged to be trademarks of their respective holders.

© 2012 QSA Global, Inc